

Product data

Features

- Highly miniaturized linear encoder
- Differential inductive sensing principle
- Insensitive to magnetic interference fields
- Robust against oil, water, dust, particles
- Ultra-thin encoder and scale (each 0.9 mm)
- Optional with cable, connector and holder

Applications

- Linear actuators
- Industrial / laboratory / office automation
- X-Y stages
- Pick & Place assembly equipment
- High-speed motion control
- Mechatronics applications

Key Specifications

Output format.....	A and B in quadrature
Resolution.....	0.3 mm – 0.3 μ m
Maximum speed	up to 40 m/s
Airgap	up to 0.7 mm
Supply.....	5 V, 12 mA
Temperature	0 – 100°C

Description

The ID1101L incremental encoder kit consists of an encoder and a linear scale. The dual-channel encoder provides incremental A and B output signals in quadrature. The resolution is programmed ex-factory from 0.3 mm down to 0.3 μ m. The linear scale is made of PCB-material and can be cut to the required length.

Resolution, maximum speed and airgap

The resolution (expressed in μ m) is defined as one state length S as shown in Figure 2. The best possible resolution that can be attained depends on the Signal to Noise Ratio (SNR). The noise depends on the bandwidth and thus on the maximum speed. The signal depends on the distance between sensor and scale (the signal increases exponentially when the airgap is reduced). The resolution, maximum speed and the airgap are thus dependent on each other, as shown in the tables 2 and 3.

Mechanical assembly

The encoder has two half-holes that allow a precise mechanical alignment of the encoder by means of two pins with diameter 1 mm. The drawing of the encoder in Fig. 3 shows the precise location of the two half-holes. The drawing of the encoder-holder in Fig. 5 shows the location of the holes for the alignment pins.

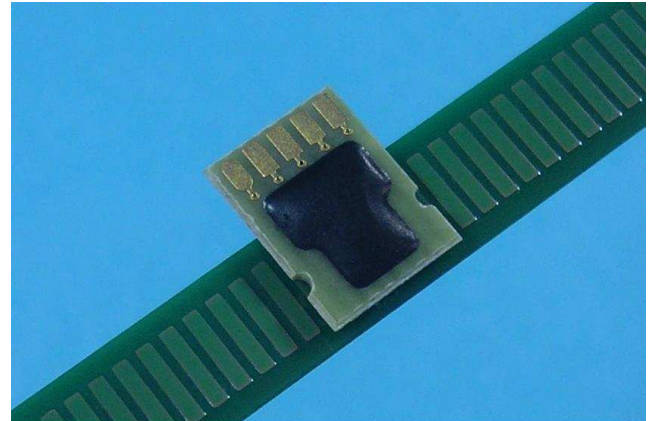

The encoder is typically glued in an encoder-holder. If the holder is ferromagnetic and/or electrically conducting, the surface behind the sensor-center (see Fig. 3) must be flat and homogeneous over a diameter of at least 5 mm. This is not required for an encoder-holder that is not ferromagnetic and not electrically conducting. The linear scale has a flat backside and can be slightly bent, which allows an easy mounting. Any of the four sides of the scale can be used for mechanical alignment.

Accessories

Encoder-holder

The encoder-holder (optional) consists of 3.2 mm thick FR4-material and has 4 screwholes for easy mounting. The holder includes a strain-relief for the cable. Fig. 5 shows the technical drawing of the encoder-holder.

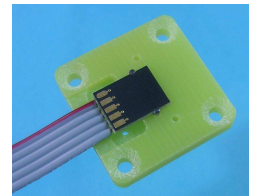

Cable and connector

The encoder is supplied with cable and connector. The cable is a standard flat cable with 5 wires at a pitch of 1.27 mm. Different connectors according to DIN41651 as well as a 6-pin MicroMaTch connector are available as standard options.



Encoder and scale customization.

Customization of encoders and/or scales for a specific application is offered as an engineering service by POSIC. For more information, contact POSIC directly.

3D models of encoder and scale

3D models (STEP- and IGS) can be downloaded from POSIC's website.

Specifications

Recommended Operating Conditions

Parameter	Symbol	Remark	Min	Typ	Max	Unit
Supply voltage	VDD		4.5	5.0	5.5	V
Operating Temperature	T _A		0		100	°C
Operating frequency	F	See Table 3			200	kHz
Airgap	Z			0.2		mm
Lateral tolerance	ΔY				0.2	mm
Airgap tolerance	ΔZ				0.1	mm

Electrical Characteristics

Electrical characteristics over recommended operating conditions, typical values at VDD = 5.0 V, T_A = 25°C.

Parameter	Symbol	Remark	Min	Typ	Max	Unit
Supply current	IDD	No load	8	12	20	mA
High level output voltage	V _{OH}	I _L = 2 mA	VDD-0.5			V
Low level output voltage	V _{OL}	I _L = 2 mA			0.5	V
Rise time	t _r	C _L = 47 pF			20	ns
Fall time	t _f	C _L = 47 pF			20	ns

Encoding Characteristics

Encoding characteristics over recommended operating conditions, typical values at VDD = 5.0 V, T_A = 25°C, airgap = 0.2 mm, speed = max speed/10.

Parameter	Symbol	Remark	Min	Typ	Max	Unit
Pulse width error	ΔP	Nominal value 180°		10	50	°
State width error	ΔS	Nominal value 90°		10	60	°
Phase shift error	ΔΦ	Nominal value 90°		10	45	°

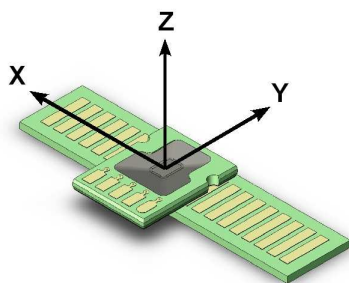

Fig. 1 Coordinate system of encoder.

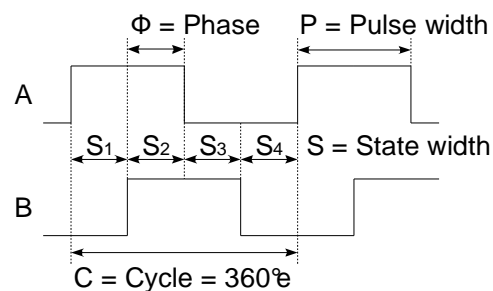

Fig. 2 Encoder output signals A and B in quadrature.

Technical drawings

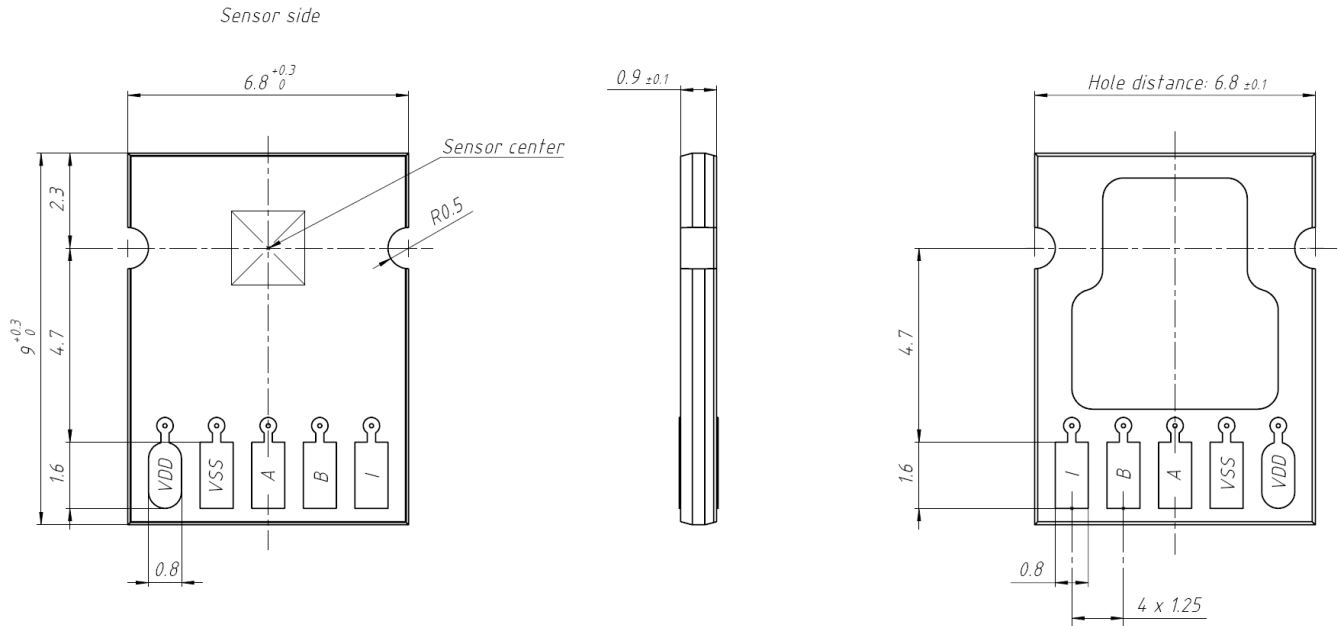

Fig. 3 Sensor dimensions and connections. The "Sensor center" must be centered with respect to the linear scale (Fig. 4).

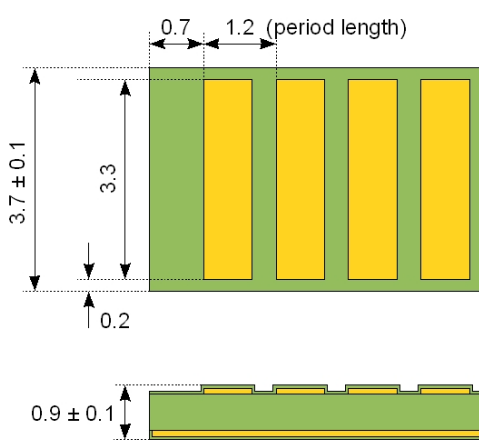

Fig. 4 Linear scale with period length = 1.2 mm (drawing not to scale).

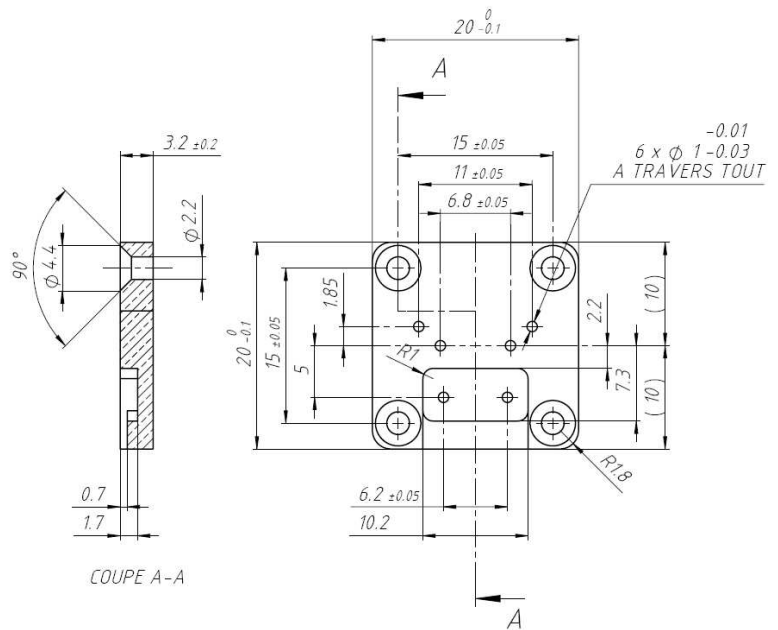

Fig. 5 Encoder Holder type A (see Table 5).

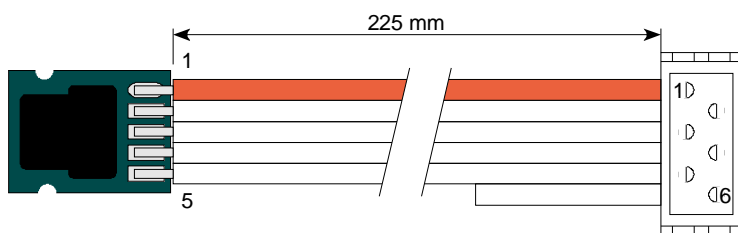

Fig. 6 Encoder with flat cable (pitch 1.27 mm) and 6-pin MicroMaTch connector.

Connector pin	Name	Description
1	VDD	5V Supply
2	VSS	Ground
3	A	Output A
4	B	Output B
5	I	Output Index
6	NC	Not Connected

Ordering information

Ordering code: ID1101L-ABBCC-DDDDEEEFFF

A	Orientation	Table 1
BB	Maximum speed	Table 2
CC	Resolution	Table 3
DDDD	Linear scale	Table 4
EEEE	Encoder holder and cable	Table 5
FF	Connector	Table 6

Table 1: Orientation

A	Orientation	Direction scale movement <i>DIR</i>
0	0°	Rising edge A prior to B
1	90°	Rising edge A prior to B

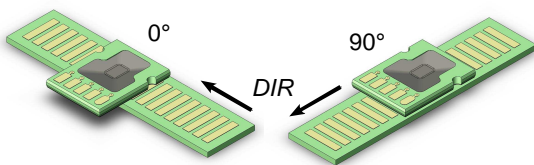

Table 2: Maximum speed

BB	Max speed (m/s)	Resolution (µm)
00	0.012	≥ 0.3
01	0.024	≥ 0.3
02	0.047	≥ 0.3
03	0.094	≥ 0.3
04	0.19	≥ 1.2
05	0.38	≥ 1.2
06	0.75	≥ 4.7
07	1.5	≥ 4.7
08	3.0	≥ 4.7
09	6.0	≥ 9.4
10	12	≥ 18.8
11	24	≥ 37.5
12	40	≥ 75

Lower Max speed leads to a lower jitter of the A/B outputs.

Table 3: Resolution

CC	Resolution		Max speed (m/s)	Max counting Airgap* (mm)
	CPP	µm		
03	2	150	40	0.7
04	4	75	40	0.6
05	8	37.5	30	0.5
06	16	18.8	15	0.4
07	32	9.4	7.5	0.3

08	64	4.7	3.75	0.3
10	256	1.2	0.5	0.3
11	512	0.6	0.12	0.2
12	1024	0.3	0.12	0.2

* Encoder is calibrated at airgap = 0.2 mm, which is recommended as nominal value. Sequence of A and B transitions is correct up to Max counting Airgap, but encoding specifications may be out of range.

Table 4: Linear scale

DDDD	Linear scale
0xxx	Cut to length xx mm (5 – 205 mm)

Other scales available upon request.

Table 5: Encoder holder and cable

EEEE	Encoder holder and cable
00xx	No holder, xx cm flat cable
A0xx	Holder type A (Fig. 5) and xx cm flat cable

Other encoder holders and cables available upon request.

Table 6: Connector

FF	Connector
01	6-pin conn. AMP MicroMaTch 7-215083-6
02	6-pin connector DIN 41651
03	14-pin connector DIN 41651

Other connectors available upon request.

Definitions

Airgap	Distance between encoder and scale in Z-direction. See Fig. 1.
Count	See Cycle.
Cycle	One A quad B period, see Fig. 2.
CPP	Cycles/Counts per scale-period of 1.2 mm.
DIR	Direction of movement of the linear scale.
°	Electrical degree (one Cycle is 360°)
Phase shift Φ	Number of electrical degrees between the center of the high state of channel A and the center of the high state of channel B. Nominal values is 90°. See Fig. 2.
Pulse width P	Number of electrical degrees that an output is high during one cycle. Nominal value is 180°. See Fig. 2.
State width S	Number of electrical degrees between two neighboring A and B transitions. Nominal value is 90°. See Fig 2.

© Copyright 2010 POSIC. All rights reserved. No part of this document may be reproduced without the prior written consent of POSIC. Products and companies mentioned in this document may be trademarks or registered trademarks of their respective owners.

Information in this document is believed to be accurate and reliable and may be changed without notice. No responsibility is assumed by POSIC for its use, nor for infringements of patents or other rights of third parties which may result from its use. Some commercial or geographical restrictions may apply to the sale of this product. No license is granted by implication or otherwise under any patent or patent rights of POSIC. In no event shall POSIC, its employees, its contractors, or the authors of this document be liable for special, direct, indirect, or consequential damage, losses, costs, charges, claims, demands, claim for lost profits, fees, or expenses of any nature or kind.

POSIC products are not designed, intended, authorized or warranted to be suitable for use in life-support applications, devices or systems or other critical care applications. Inclusion of POSIC products in such applications is understood to be undertaken solely at the customer's own risk. Should a customer purchase or use POSIC products for any such unauthorized application, the customer shall indemnify and hold POSIC and its officers, employees, subsidiaries, affiliates, representatives and distributors harmless against all claims, costs, damages and attorney fees which could arise.