

AP5603L Dual-track Absolute Linear Encoder Kit with SSI outputs

Product data

Features

- Highly miniaturized encoder
- Differential inductive sensing principle
- Insensitive to magnetic interference fields
- Robust against oil, water, dust, particles
- Ultra-thin encoder and scale (total < 2 mm)
- Optional with cable, connector and holder

Applications

- Linear actuators
- Industrial / laboratory automation
- X-Y stages
- Pick & Place assembly equipment
- Medical infusion pumps

Key Specifications

Output format.....SSI
 Absolute position rangeup to 19 mm
 Resolution.....14 bit / scale-period of 1.2 mm
 Maximum speedup to 15 m/s
 Airgapup to 0.5 mm
 Supply.....5 V, 30 mA
 Temperature-20 to 100°C

Description

The AP5603L absolute encoder kit consists of an encoder and a linear scale (Fig. 1). The encoder consists of two integrated circuits in a PCB housing. Each circuit provides an SSI output (Fig. 2). The linear scale is a PCB with passive copper strips arranged in 2 tracks with an unequal number of periods N1 and N2 (Fig. 4 and Table 5). The absolute position is calculated by subtracting the two SSI values. The algorithm for this calculation is available from POSIC.

Maximum speed

The maximum speed of the encoder is user-programmable or can be programmed ex-factory according to Table 2.

SSI code

The SSI code is Gray or binary and is user-programmable or can be programmed ex-factory according to Table 3.

Scales

Scales with different absolute measurement ranges are available and are selected in Table 5. The scale may be mounted on any substrate, using an alignment edge ≤ 0.2 mm for accurate positioning in front of the encoder.

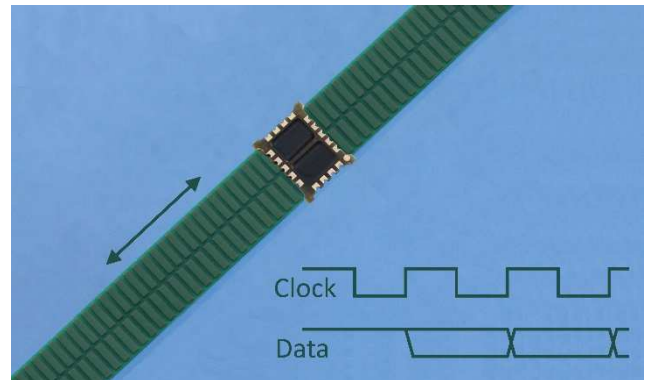
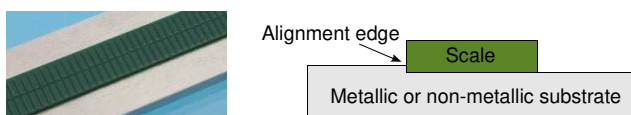

Encoder assembly

The encoder can be assembled by reflow soldering on a rigid or flexible PCB. Optimum performances are obtained by following the recommended schematic (Fig. 5) and footprint (Fig. 6). In particular, there should be no copper traces or metal objects behind the encoder up to a distance of 3 mm in order to avoid any influence on the measured position. If this is not possible, a blank copper layer behind the encoder (rear-side of the PCB) may be envisaged and/or a linearization using the on-chip look-up table (LUT).

Encoder holder

The encoder holder **type A** is available (Fig. 7) and can be selected in Table 6. It includes the encoder and the external components according to the recommended schematic (Fig. 5). The encoder holder can be mounted on any substrate using 4 screw holes.

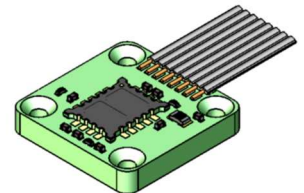

Encoder cable and connector

The encoder on holder can be supplied with a flat cable of pitch 1.27 mm and a connector (Fig. 7). The cable length and the connector type are selected in Tables 7 and 8.

Encoder programming

The Evaluation and Programming Tool (EPT) including an interface board and the ASSIST software is available for the linearization and programming of the encoder.

3D models of encoder, holder and scales

STEP models are available on www.posic.com.

Specifications

Recommended Operating Conditions

Parameter	Symbol	Remark	Min	Typ	Max	Unit
Supply voltage	VDD		4.5	5.0	5.5	V
Operating Temperature	T _A		-20		100	°C
SSI clock frequency	F _{SSIClock}		25		600	kHz
SSI Wait time	t _{SSWait}	Time between SSI-frames	100			us
Airgap*	Z			0.2	0.5	mm
Lateral tolerance	ΔY				0.1	mm
Airgap tolerance	ΔZ				0.1	mm

Max Airgap depends on max speed (Table 2), linearization (Table 4) and scale (Table 5).

Electrical Characteristics

Electrical characteristics over recommended operating conditions, typical values at VDD = 5.0 V, T_A = 25°C.

Parameter	Symbol	Remark	Min	Typ	Max	Unit
Supply current	IDD	No load	15	30	45	mA
SSI Time out	t _{SSTimeout}	Time-out after SSI-frame	22	65	95	us
Derating for Max speed, Table 2		Temp range 0 to 65°C Temp range -20 to 100°C			-8 -14	%
High level output voltage	V _{OH}	I _L = 2 mA	VDD-0.5			V
Low level output voltage	V _{OL}	I _L = 2 mA			0.5	V
Rise time, fall time	t _r , t _f	C _L = 47 pF			20	ns

Linearity

For high-resolution high-precision applications, it is possible to linearize the encoder by means of a Look-Up Table (LUT) that is located inside the encoder. The LUT can be programmed in volatile or in non-volatile memory by means of the Evaluation and Programming Tool (EPT) or it can be pre-programmed ex-factory. The LUT option is selected in Table 4.

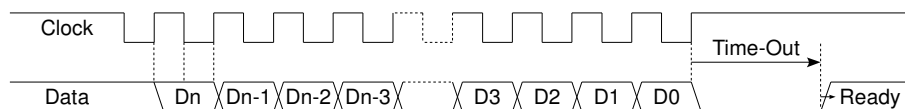

Fig. 2A SSI protocol when the complete data-word is read. D_n is most significant bit, D₀ is least significant bit. After the time-out, the encoder is "ready" to transmit the next SSI-data-word. The length of the data-word is 14 bits, the coding can be selected Binary or Gray (Table 3). The data-word represents the position within one period of the scale.

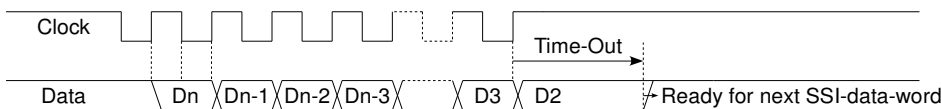

Fig. 2B SSI protocol when data-word is read partially. After time-out, the encoder is "ready" to transmit the next SSI-data-word.

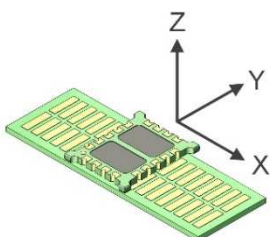

Fig. 1 Coordinate system XYZ.

Definitions

Airgap	Distance between encoder and scale in Z-direction. See Fig. 1.
°e	Electrical degree (one Cycle is 360°e)
SSI	Serial Synchronous Interface
Period	One copper strip on a linear scale

Technical drawings

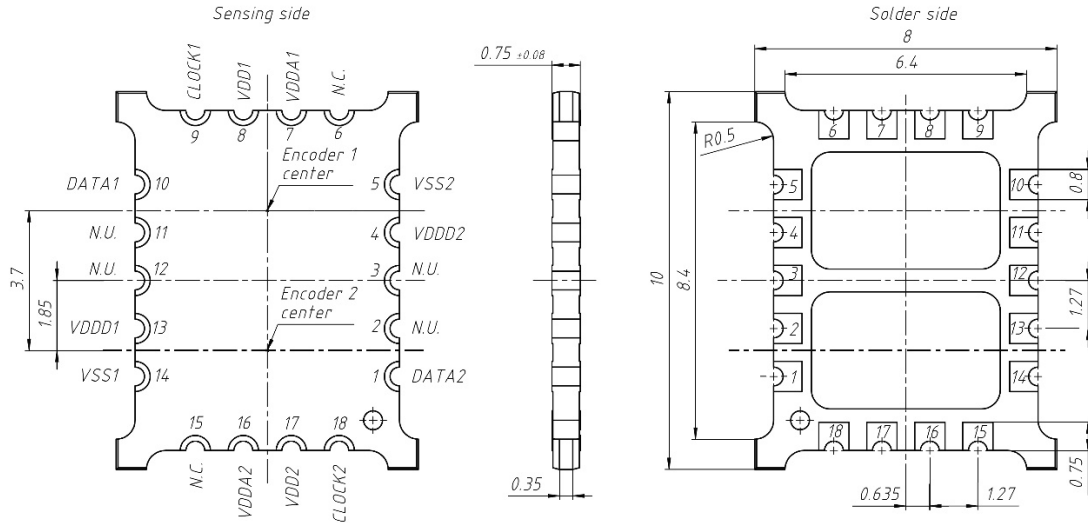
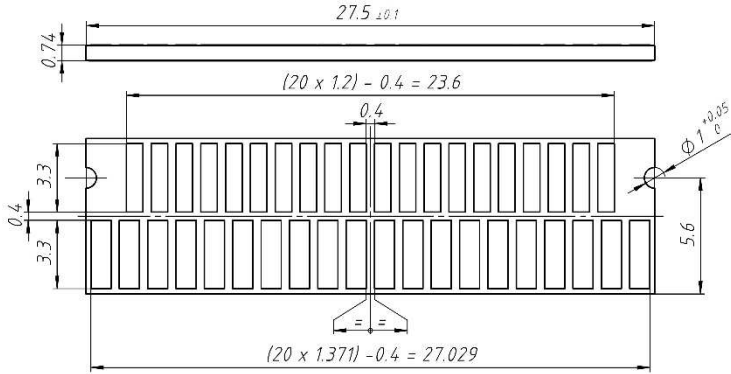

Fig. 3 Dimensions and pin-out of AP5603 encoder. Encoder 1 center must be aligned to Track 1 center (Fig 4) and Encoder 2 to Track 2.



Scale	Absolute stroke		Period length mm		Length of scale mm
	Periods	mm	Track 1	Track 2	
TPLA08	8	9.6	1.2	1.371	27.5
TPLA16	16	19.2	1.2	1.280	35.9
TPLA32	32	38.4	1.2	1.239	54.6

Fig. 4 Dimensions of linear Nonius-scales TPLA08, TPLA16 and TPLA32. Track 1 is marked by 2 half-holes.

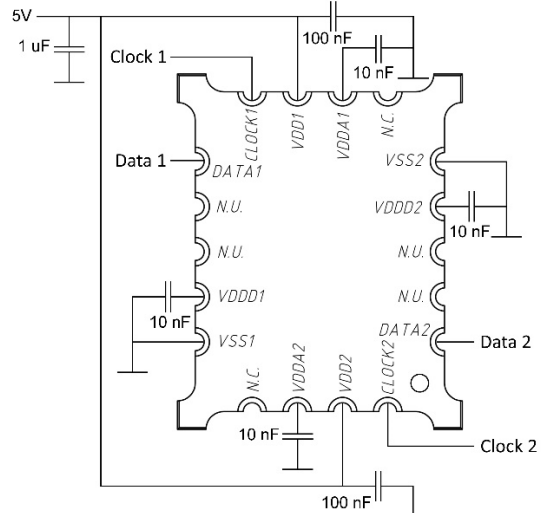

Fig. 5 Recommended schematic. N.C. = Not Connected. N.U. = Not Used. N.C. and N.U. pins may be floating or connected to ground (VSS). The supply filter capacitor should be 1µF or more. The capacitors 100nF and 10nF should be placed close to the device.

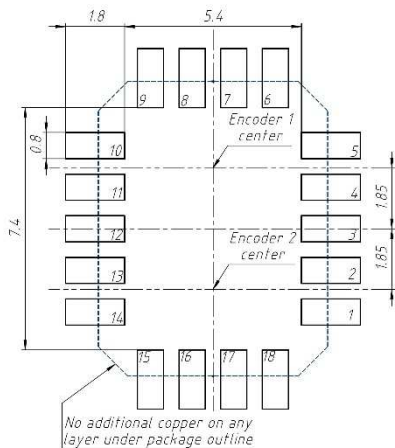

Fig 6 Recommended footprint.

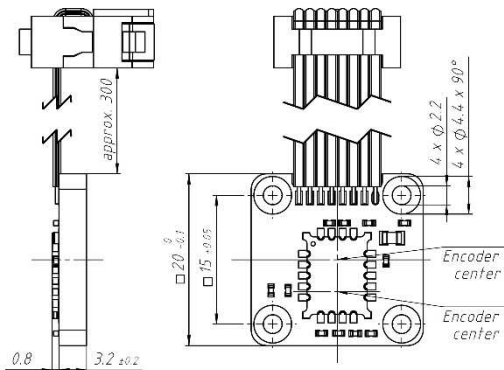

Fig. 7 Dimensions (mm) and connector pin-out of encoder on holder type A with flat cable (pitch 1.27 mm) and 8-pin DIN41651 connector.

Pin	Name	Description
1	VDD	5V Supply
2	VSS	Ground
3	SCK1	Clock 1
4	SIO1	Data 1
5	N.U.	Not Used
6	SCK2	Clock 2
7	SIO2	Data 2
8	N.U.	Not Used

Ordering information

Ordering code: AP5603L-ABBCCD-EEEE-F-GGG-HH		
A	Orientation	Table 1
BB	Maximum speed	Table 2
CC	SSI code	Table 3
D	Look-Up Table	Table 4
EEEE	Linear scale	Table 5
F	Encoder holder	Table 6
GGG	Cable	Table 7
HH	Connector	Table 8

Table 1: Orientation. Arrows indicate direction of movement of the scale with increasing position.

A	Orientation
0	Not progr. (default 0°)
3	0°
5	180°

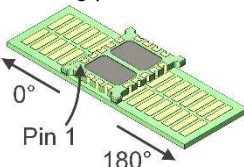

Table 2: Maximum speed

BB	Max speed (m/s)*	Typical delay (ms)
00	Not programmed (default 0.005 m/s)	
01	0.014	30
02	0.029	15
03	0.058	8
04	0.11	4
05	0.23	2
06	0.46	1
07	0.93	0.5
08	1.8	0.25
09	3.7	0.13
21	7.5	0 at const. speed
22	15.0	0 at const. speed

*Max speed valid at 25°C, temp. derating in specs, page 2. Lower Max speed leads to lower position-noise.

Table 3: SSI Code

CC	SSI Code
00	Not programmed (default Gray)
01	Binary
02	Gray

Table 4: Look-Up Table (LUT)

D	Look-Up Table programmed in OTP
0	Not programmed
1	LUT according to scale, to be specified
8	Custom LUT, to be specified
9	Default LUT, no scale specified

Table 5: Linear scale (Fig 4)

EEEE	N1	N2	Absolute stroke (mm)	Scale length (mm)
00000	No scale			
08028	8	7	9.6	27.5
16036	16	15	19.2	35.9
32055	32	31	38.4	54.6

The absolute stroke corresponds to N1 periods on track 1 and N2 periods on track 2. The scale is made of FR4-material and can be cut to the desired length.

Table 6: Encoder holder

F	Encoder holder
0	No holder
A	Holder A (Fig. 5)

Table 7: Cable

GGG	Cable
000	No cable
0xx	Flat ribbon cable, length xx cm

Max cable length 99 cm

Table 8: Connector

HH	Connector
00	No connector
04	8-pin connector DIN 41651 (Fig. 6)

© Copyright 2021 POSIC. All rights reserved. No part of this document may be reproduced without the prior written consent of POSIC. Products and companies mentioned in this document may be trademarks or registered trademarks of their respective owners. Information in this document is believed to be accurate and reliable and may be changed without notice. No responsibility is assumed by POSIC for its use, nor for infringements of patents or other rights of third parties which may result from its use. Some commercial or geographical restrictions may apply to the sale of this product. No license is granted by implication or otherwise under any patent or patent rights of POSIC. In no event shall POSIC, its employees, its contractors, or the authors of this document be liable for special, direct, indirect, or consequential damage, losses, costs, charges, claims, demands, claim for lost profits, fees, or expenses of any nature or kind. POSIC products are not designed, intended, authorized or warranted to be suitable for use in life-support applications, devices or systems or other critical care applications. Inclusion of POSIC products in such applications is understood to be undertaken solely at the customer's own risk. Should a customer purchase or use POSIC products for any such unauthorized application, the customer shall indemnify and hold POSIC and its officers, employees, subsidiaries, affiliates, representatives and distributors harmless against all claims, costs, damages and attorney fees which could arise.