

Product data

Features

- Highly miniaturized encoder
- Differential inductive sensing principle
- Insensitive to magnetic interference fields
- Robust against oil, water, dust, particles
- Profile-height encoder + scale < 5 mm
- Absolute position upon power-on

Applications

- Robotics
- Linear actuators
- Industrial / laboratory / office automation
- X-Y stages
- Pick & Place assembly equipment

Key Specifications

Output format.....SSI
 Absolute position rangeup to 19 mm
 Resolution.....down to 0.02 μm
 Maximum speedup to 15 m/s
 Airgapup to 0.5 mm
 Supply.....5 V, 70 mA
 Temperature-20 to 100°C

Description

The AP9201L absolute encoder kit consists of an encoder and a linear scale (Fig. 1). The encoder consists of a printed circuit board with a 2-track encoder-chip AP5603L on the frontside and a microcontroller on the backside. The microcontroller reads out the encoder-chip, calculates the absolute position and converts this into a binary SSI code. The output is a Serial Synchronous Interface SSI with single-ended 5V signals. The linear scale is a PCB with passive copper strips arranged in 2 tracks with an unequal number of periods N1 and N2 (Fig. 8 and Table 5).

Maximum speed

The maximum speed of the encoder is user-programmable or can be programmed ex-factory according to Table 2.

Scales

Scales with different absolute measurement ranges are available and are selected in Table 5. The scale may be mounted on any substrate, using an alignment edge < 0.2 mm for accurate positioning in front of the encoder.

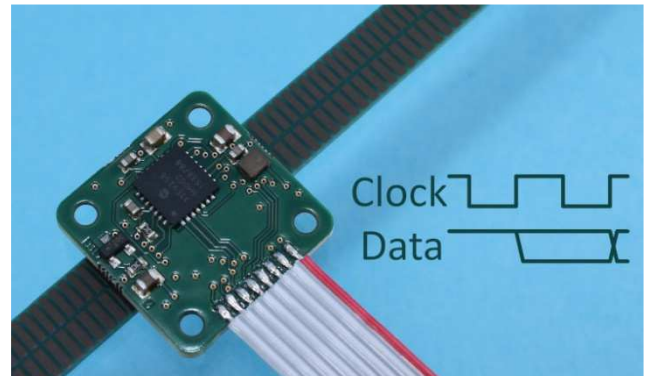
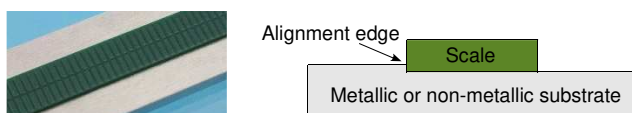

Encoder assembly

The encoder has 4 screwholes and is delivered with 4 spacers (Fig. 7) that allow an easy assembly.

Encoder cable and connector

The encoder is optionally equipped with a flat ribbon cable of pitch 1.27 mm and an 8-pin DIN 41651 connector. The cable length and the connector type are selected in Tables 7 and 8.

Encoder programming

The Evaluation and Programming Tool (EPT) including an interface board and the ASSIST software is available for the linearization and programming of the encoder.

3D models of encoder, holder and scales

3D STEP models of the encoder, the scale and the spacers are available on www.posic.com.

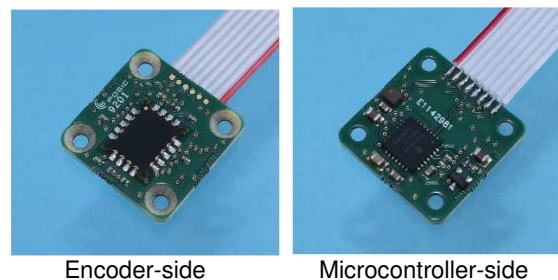

Encoder-side

Microcontroller-side

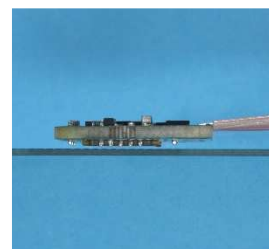

Profile-height Encoder + Scale < 5 mm

Specifications

Recommended Operating Conditions

Parameter	Symbol	Remark	Min	Typ	Max	Unit
Supply voltage	VDD		4.75	5.0	5.25	V
Operating Temperature	T _A		-20		100	°C
Airgap*	Z			0.2	0.5	mm
Lateral tolerance	ΔY				0.1	mm
Airgap tolerance	ΔZ				0.1	mm

Max Airgap depends on max speed (Table 2), linearization (Table 4) and scale (Table 5).

Electrical Characteristics

Electrical characteristics over recommended operating conditions, typical values at VDD = 5.0 V, T_A = 25°C.

Parameter	Symbol	Remark	Min	Typ	Max	Unit
Supply current	I _{DD}	No load	50	65	80	mA
Derating for Max speed, Table 2		Temp range 0 to 65°C Temp range -20 to 100°C			-8 -14	%

SSI

Parameter	Symbol	Remark	Min	Typ	Max	Unit
SSI clock frequency	F _{SSIClock}		0.2	1	1.2	MHz
SSI Wait time	t _{SSIwait}	Time between SSI-frames		20		us
Resolution		Bits per period of 1.2 mm Length of 1 LSB		16 0.02		Bits μm
Refresh rate	F _{refresh}			30		kHz

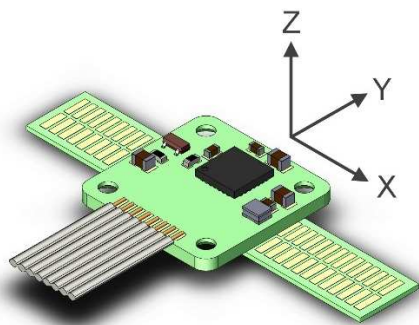

Fig. 1 Coordinate system XYZ.

Definitions

Airgap	Distance between encoder and scale in Z-direction. See Fig. 1.
°e	Electrical degree (one Cycle is 360°e)
SSI	Serial Synchronous Interface
Period	One copper strip on a linear scale

SSI Description

Transmission protocol

Bit nr.	30	29	28	...	8	7	6	5	4	3	2	1	0
Description	nE	Pos(22:0)					nW	CRC(5:0)					

Bit	Data field	Description
30	nE	No Error 1: Position data is valid 0: Position data is not valid
29:7	Pos(22:0)	Position, left aligned, transmitted MSB first Scale TPLA08: 16 bits per period x 8 periods = 19 bits over absolute range of 9.6 mm in Pos(22:3) Scale TPLA16: 16 bits per period x 16 periods = 20 bits over absolute range of 19.2 mm in Pos(22:2) Scale TPLA32: 16 bits per period x 32 periods = 21 bits over absolute range of 38.4 mm in Pos(22:1)
6	nW	No Warning 1: Position data is valid 0: Position data is valid, but some operational conditions may be close to the limits and the position data may be out of specification
5:0	CRC(5:0)	Cyclic Redundancy Check. The polynomial for the CRC calculation is x^6+x+1 . The initial value is 0 and the bits are transmitted inverted.

Normal transmission

A single data frame consist of 31 bit (Fig. 2). On the leading clock edge sent by the controller, the encoder fetches the latest position data. This data is made available on the subsequent rising edges of the incoming clock signal. Once all 31 bits are sent, the data output is forced to 0 until the end of the clock time-out period. The output is forced to 1 when the time-out expires. The encoder is then ready for the transmission of new position data.

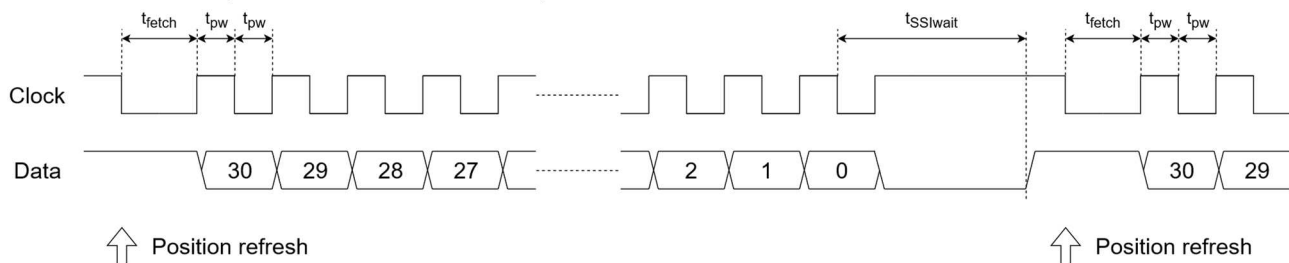

Fig. 2 SSI frame timing diagram for normal transmission.

Partial transmission

It is not mandatory to read the full 31 bit data frame. If only the first part of the frame is of interest for the controller, it can stop the transmission of the frame by holding the clock line high for a period exceeding the clock time-out. At the next falling edge of the clock, the position data will be refreshed and a new data frame started. Figure xx shows an example where only the first 8 bit of the frame are read.

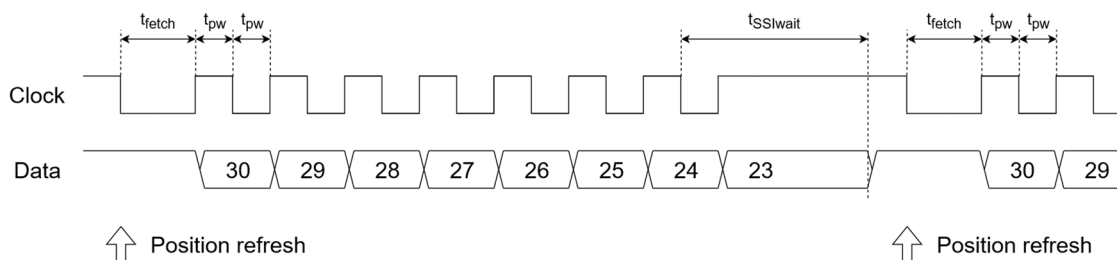

Fig. 3 SSI frame timing diagram for partial transmission, only the initial 8 bits are transmitted.

Position update rate

The internal position calculation engine has a fixed update period t_{update} as shown in Fig. 4. The data that will be sent by the SSI will depend on the timing of the SSI frame leading clock edge with respect to the internal position calculation engine. If the SSI frame repetition rate is faster than the internal position calculation engine update rate, it may send twice the same position. If the SSI frame repetition rate is slower than the internal position calculation engine update rate, some of the internally calculated positions will be skipped.

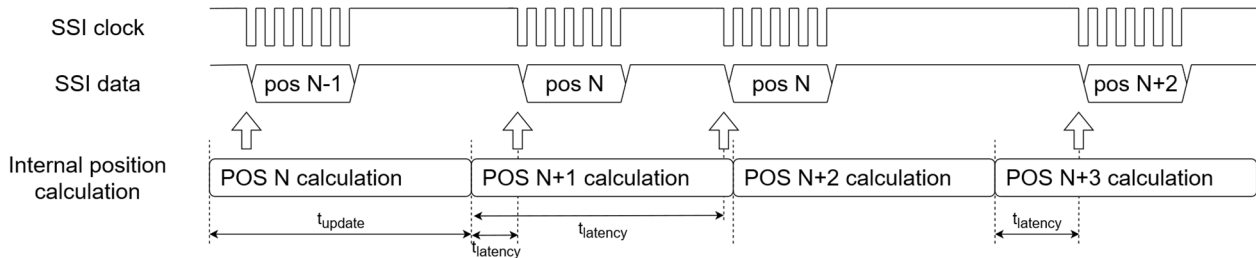

Fig. 4 Timing diagram showing the relation between the encoder-internal position calculation and the SSI output data.

Re-transmission

The encoder also implements the SSI multiple transmission mode: if an additional clock cycle is present before the expiration of the clock time-out at the end of the message, the position information is not updated and the exact same message is repeated (Fig. 5).

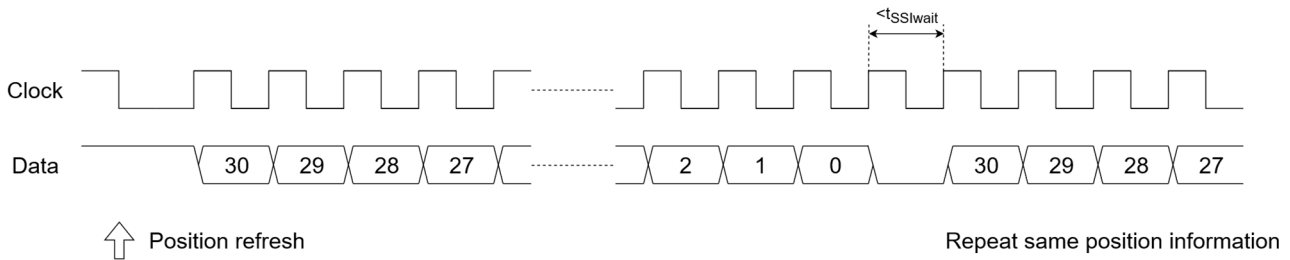
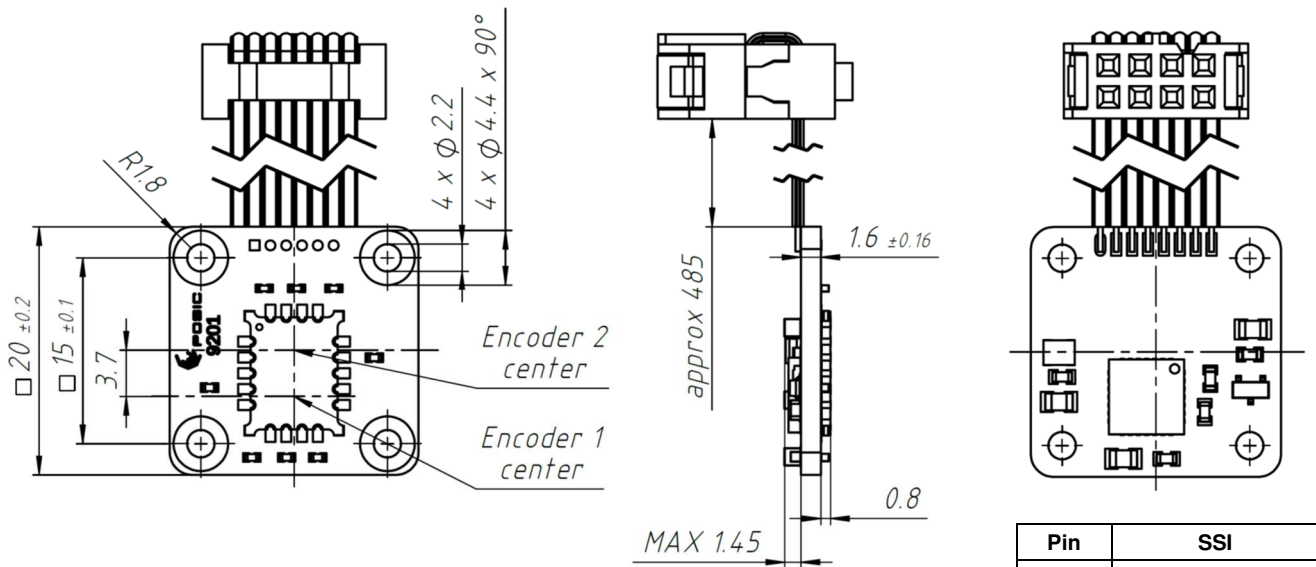

Fig. 5 SSI frame timing diagram for re-transmission of the previous data.

Linearity

For optimum performance, it is recommended to linearize the encoder by means of a Look-Up Table (LUT) that is located inside the microcontroller. The LUT can be programmed by the user or it can be pre-programmed ex-factory by POSIC. The LUT option is selected in Table 4.

Technical drawings



Pin	SSI
1	5V Supply
2	Ground
3	Clock
4	Data
5	Do not connect
6	Do not connect
7	Do not connect
8	Do not connect

Fig. 6 Dimensions and pin-out of AP9201 encoder. Encoder 1 center must be aligned to Track 1 center (Fig. 8) and Encoder 2 to Track 2. The height of the components on the backside of the encoder is 1.45 mm maximum. Spacers (plastic distance rings) of 1.6 mm height are delivered with the encoder in order to mount the encoder on a flat surface without the components touching the mounting-surface.

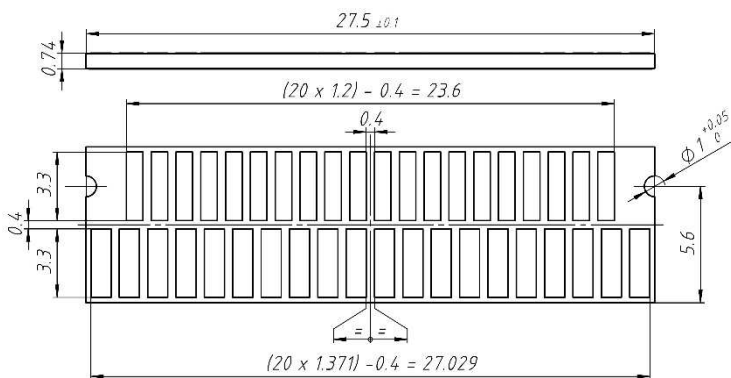

Scale	Absolute stroke		Period length mm		Length of scale mm
	Periods	mm	Track 1	Track 2	
TPLA08	8	9.6	1.2	1.371	27.5
TPLA16	16	19.2	1.2	1.280	35.9
TPLA32	32	38.4	1.2	1.239	54.6

Fig. 8 Linear 2-track Nonius scale with different period lengths. The absolute stroke corresponds to N1 periods (of 1.2 mm each) on track 1 and to N2 periods on track 2. Track 2 has N2 = N1-1 periods.

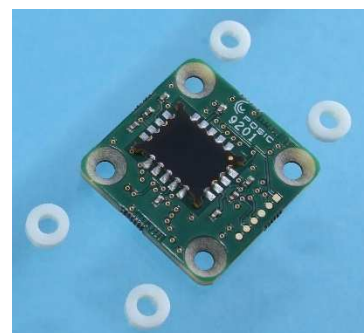

Fig. 7 Four plastic spacers (plastic distance rings) of 1.6 mm thickness are optionally (Table 6) delivered with each encoder in order to mount the encoder on a flat surface and avoid that the components on the backside touch the mounting-surface. The height of the components is 1.45 mm maximum (Fig. 6).

Ordering information

Ordering code: AP9201L-ABBCCD-EEEE-F-GGG-HH		
A	Orientation	Table 1
BB	Maximum speed	Table 2
CC	Interface	Table 3
D	Look-Up Table	Table 4
EEEE	Linear scale	Table 5
F	Spacers	Table 6
GGG	Cable	Table 7
HH	Connector	Table 8

Table 1: Orientation. Arrows indicate direction of movement of the scale with increasing position.

A	Orientation
0	Not progr. (default 0°)
3	0°
5	180°

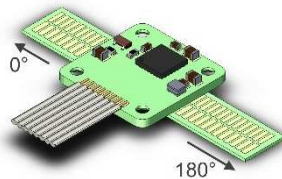

Table 2: Maximum speed

BB	Max speed (m/s)*	Typical filter-delay (ms)
00	Not programmed (default 0.014 m/s)	
01	0.014	30
02	0.029	15
03	0.058	8
04	0.11	4
05	0.23	2
06	0.46	1
07	0.93	0.5
08	1.8	0.25
09	3.7	0.125
21	7.5	0 at const. speed
22	15.0	0 at const. speed

*Max speed valid at 25°C, temp. derating in specs, page 2. Lower Max speed leads to lower position-noise.

Table 3: Interface

CC	Interface
00	Not programmed (default SSI Binary)
01	SSI, Binary

Table 4: Look-Up Table (LUT)

D	Look-Up Table programmed in OTP
0	Not programmed
1	LUT according to scale specified in Table 5
8	Custom LUT, to be specified

Table 5: Linear scale (Fig. 8)

EEEE	N1	N2	Max absolute range (mm)	Total scale length (mm)
00000	No scale			
08028	8	7	9.6	27.5
16036	16	15	19.2	35.9
32055	32	31	38.4	54.6

The absolute stroke corresponds to N1 periods on track 1 and N2 periods on track 2. The scale is made of FR4-material and can be cut to the desired length.

Table 6: Spacers (distance rings, Fig. 7)

F	Spacers
0	No spacers
1	Including 4 spacers

Table 7: Cable

GGG	Flat ribbon cable
000	No cable
050	Length 50
100	Length 100 cm

Cable temperature range: -20 to 80°C.

Table 8: Connector

HH	Connector
00	No connector
04	8-pin connector DIN 41651 (Fig. 6)

© Copyright 2021 POSIC. All rights reserved. No part of this document may be reproduced without the prior written consent of POSIC. Products and companies mentioned in this document may be trademarks or registered trademarks of their respective owners. Information in this document is believed to be accurate and reliable and may be changed without notice. No responsibility is assumed by POSIC for its use, nor for infringements of patents or other rights of third parties which may result from its use. Some commercial or geographical restrictions may apply to the sale of this product. No license is granted by implication or otherwise under any patent or patent rights of POSIC. In no event shall POSIC, its employees, its contractors, or the authors of this document be liable for special, direct, indirect, or consequential damage, losses, costs, charges, claims, demands, claim for lost profits, fees, or expenses of any nature or kind. POSIC products are not designed, intended, authorized or warranted to be suitable for use in life-support applications, devices or systems or other critical care applications. Inclusion of POSIC products in such applications is understood to be undertaken solely at the customer's own risk. Should a customer purchase or use POSIC products for any such unauthorized application, the customer shall indemnify and hold POSIC and its officers, employees, subsidiaries, affiliates, representatives and distributors harmless against all claims, costs, damages and attorney fees which could arise.