

Product data

Features

- Highly miniaturized linear encoder
- Differential inductive sensing principle
- Insensitive to magnetic interference fields
- Robust against oil, water, dust, particles
- Programmable resolution and maximum speed
- Optional with cable, connector and holder

Applications

- Linear actuators
- Industrial / laboratory / office automation
- X-Y stages
- Pick & Place assembly equipment
- High-speed motion control
- Mechatronics applications

Key Specifications

Output format.....A and B in quadrature
 Resolution.....down to 0.02 μm
 Maximum speedup to 32 m/s
 Airgapup to 0.6 mm
 Supply.....5 V, 10 mA
 Temperature-20 to 100°C

Description

The ID1102L incremental encoder kit consists of an encoder and a linear scale (Fig. 1). The encoder is an integrated circuit in a PCB housing. It provides incremental A and B output signals in quadrature (Fig. 2). The linear scale is a PCB with passive copper strips. The orientation of the encoder is selected in Table 1.

Resolution, maximum speed and airgap

The resolution and the maximum speed of the encoder are user-programmable or can be programmed ex-factory. The resolution depends on a filter setting that limits the maximum speed of the encoder vs. the scale. The resolution also depends on the maximum distance between the encoder and the scale. The resolution and maximum speed for a certain maximum air-gap are selected in Tables 2 and 3.

Scales

Scales with different dimensions and period lengths are available (Fig. 4) and are selected in Table 5. The scale may be mounted on any substrate, using an edge for accurate positioning in front of the encoder.

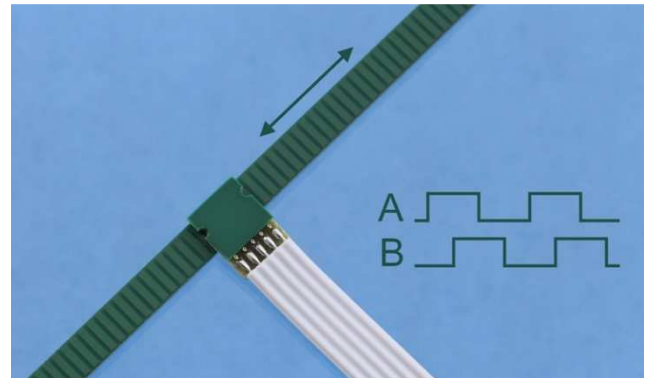
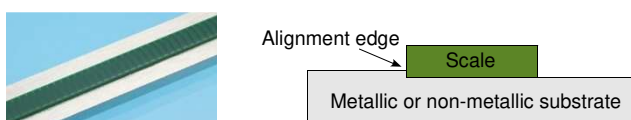

Encoder holders

Different encoder holder options are available and can be selected in Table 6.

The encoder holder **type A** (Fig. 5) may be mounted on any substrate using 4 screw-holes. It has a strain relief for the cable.

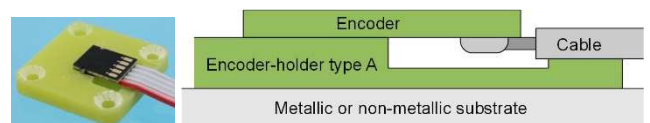

The encoder holder **type B** (Fig. 3) may be mounted on any substrate. Use half-holes on encoder PCB housing and alignment pins for accurate positioning.

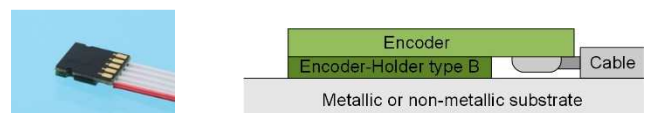

The encoder without holder may be mounted on non-metallic substrates. Use half-holes on encoder housing and alignment pins for accurate positioning.

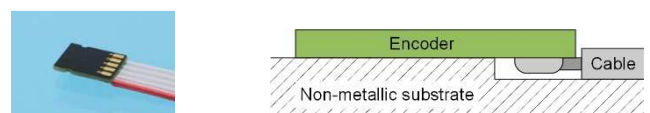

Encoder cable and connector

The encoder can be supplied with a flat cable of pitch 1.27 mm and a connector (Fig. 6). The cable length and the connector type are selected in Tables 7 and 8.

Encoder programming

The Evaluation and Programming Tool (EPT) including an interface board and the ASSIST software is available for the linearization and programming of the encoder.

3D models of encoder, holders and scales

STEP models available on www.posic.com.

Specifications

Recommended Operating Conditions

Parameter	Symbol	Remark	Min	Typ	Max	Unit
Supply voltage	VDD		4.5	5.0	5.5	V
Operating Temperature	T _A		-20		100	°C
Airgap	Z			0.2		mm
Lateral tolerance scale	ΔY	TPLS01, scale width 3.7 mm			0.2	mm
		TPLS02, scale width 4.4 mm			0.5	mm
Airgap tolerance	ΔZ				0.1	mm

Electrical Characteristics

Electrical characteristics over recommended operating conditions, typical values at VDD = 5.0 V, T_A = 25°C.

Parameter	Symbol	Remark	Min	Typ	Max	Unit
Supply current	I _{DD}	No load	8	10	15	mA
Maximum output frequency	F	A/B output signals	0.8	1	1.2	MHz
High level output voltage*	V _{OH}	I _L = 2 mA	VDD-0.5			V
Low level output voltage*	V _{OL}	I _L = 2 mA			0.5	V
Rise time, fall time	t _r , t _f	C _L = 47 pF			20	ns

If A is pulled up and B pulled down during power-up, the encoder enters into a test mode with a 50 kHz square wave on all outputs.

Encoding Characteristics

Encoding characteristics over recommended operating conditions, typical values at VDD = 5.0 V, T_A = 25°C, airgap = 0.2 mm, speed = max speed/10.

Parameter	Symbol	Remark	Min	Typ	Max	Unit
Pulse width error	ΔP	Nominal value 180°e		10	50	°e
State width error	ΔS	Nominal value 90°e		10	60	°e
Phase shift error	ΔΦ	Nominal value 90°e		10	45	°e

Linearity

For high-resolution high-precision applications, it is possible to linearize the encoder by means of a Look-Up Table (LUT) that is located inside the encoder. The LUT can be programmed in volatile or in non-volatile memory by means of the Evaluation and Programming Tool (EPT) or it can be pre-programmed by ex-factory. The LUT option is selected in Table 4.

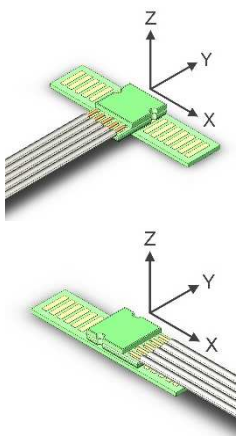

Fig. 1 Coordinate system XYZ.

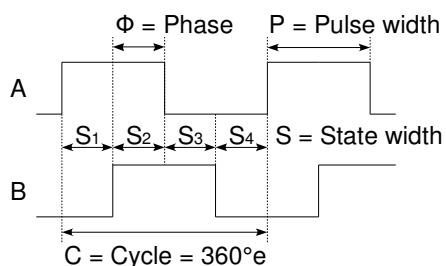

Fig. 2 Encoder output signals A and B in quadrature.

Definitions

Airgap	Distance between encoder and scale in Z-direction. See Fig. 1.
Cycle	One A quad B period, see Fig. 2.
CPP	Cycles per scale-period.
°e	Electrical degree (one Cycle is 360°e)
Phase shift Φ	Number of electrical degrees between the center of the high state of channel A and the center of high state of channel B. Nominal 90°e. Fig. 2.
Pulse width P	Number of electrical degrees that an output is high during one cycle. Nominal 180°e. Fig. 2.
State width S	Number of electrical degrees between two neighboring A and B transitions. Nominal value is 90°e. See Fig. 2.

Technical drawings

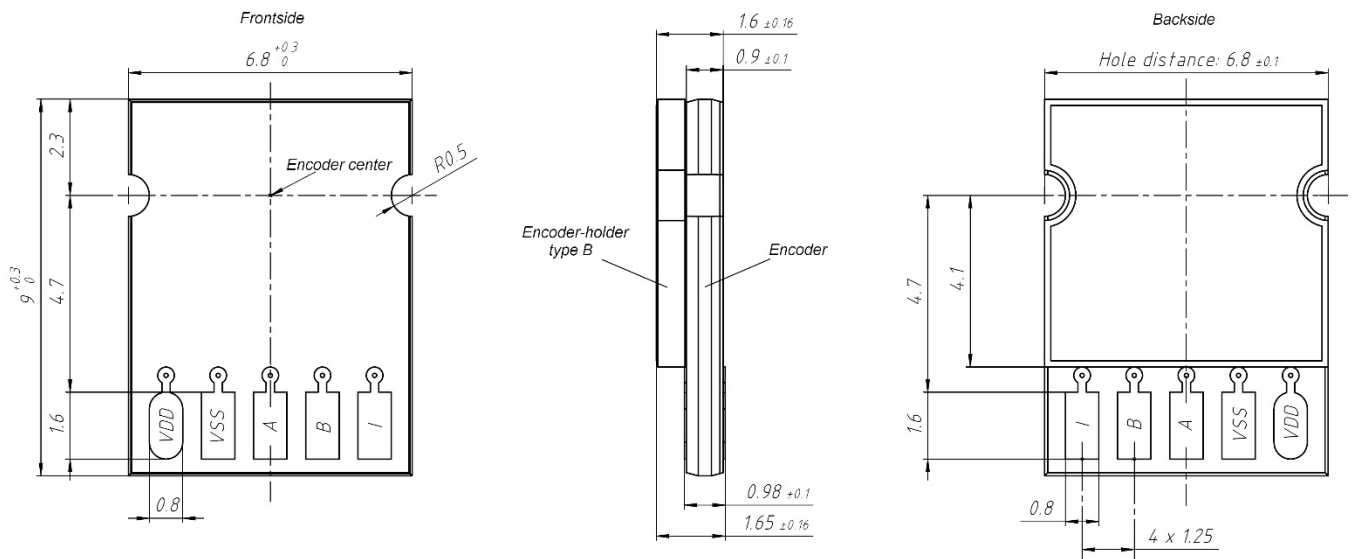
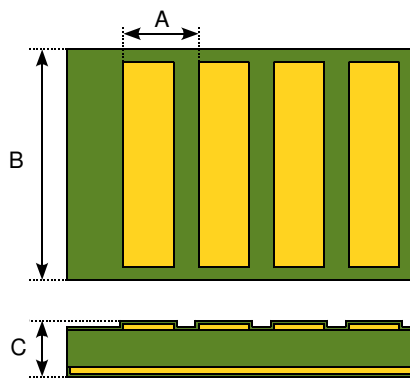

Fig. 3 Dimensions (mm) of ID1102 encoder on encoder-holder type B. The “Encoder center” must be centered with respect to the width of the linear scale (Fig. 4).



Description	Dim	TPLS01	TPLS02
Period length	A	1.20	1.28
Scale width	B	3.7 ± 0.1	4.4 ± 0.1
Thickness	C	0.73 ± 0.1	0.92 ± 0.1

Fig. 4 Scale dimensions in mm.

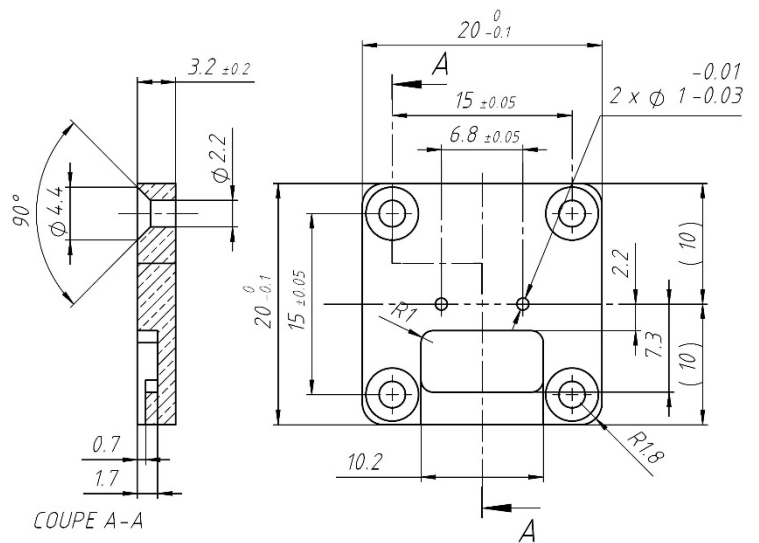

Fig. 5 Dimensions (mm) of encoder-holder type A.

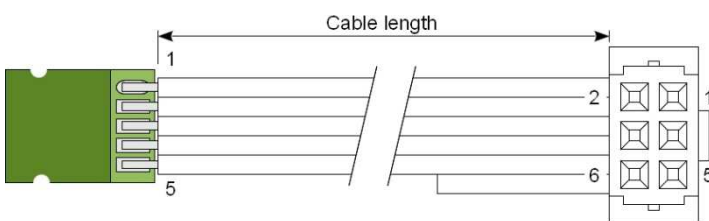

Fig. 6 Encoder with flat cable (pitch 1.27 mm) and 6-pin connector DIN41651.

Connector pin	Name	Description
1	VDD	5V Supply
2	VSS	Ground
3	A	A
4	B	B
5	I	Index (multiple)
6	NC	Not connected

Ordering information

Ordering code:	ID1102L-ABBCCD-EEEE-F-GGG-HH	
A	Orientation	Table 1
BB	Maximum speed	Table 2
CC	Resolution	Table 3
D	Look-Up Table	Table 4
EEEE	Linear scale	Table 5
F	Encoder holder	Table 6
GGG	Cable	Table 7
HH	Connector	Table 8

Table 1: Orientation. Arrows indicate direction of movement of the scale with rising edge A prior to B.

A	Orientation
0	Not progr.
3	0°
4	90°
5	180°
6	270°

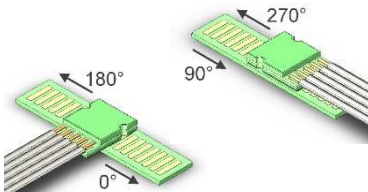

Table 2: Maximum speed

BB	Max speed (m/s)		Max value CC
	Scale period		
	1.20	1.28	
00	Not programmed		
01	0.014	0.015	16
02	0.029	0.031	16
03	0.058	0.062	16
04	0.11	0.12	15
05	0.23	0.25	14
06	0.46	0.5	13
07	0.93	1	12
08	1.8	2	11
09	3.7	4	10
21	7.5	8	09
22	15	16	08
23	30	32	07

Lower Max speed leads to a lower jitter of the A/B outputs.

Table 3: Resolution

CC	CPP	Resolution		Max value BB	Maximum Airgap* (mm)
		Scale period			
		1.20	1.28		
00	Not programmed				
03	2	150	160	23	0.6
04	4	75	80	23	0.6
05	8	37.5	40	23	0.6

06	16	18.75	20	23	0.6
07	32	9.38	10	23	0.6
08	64	4.69	5	22	0.5
09	128	2.34	2.5	21	0.5
10	256	1.17	1.25	09	0.4
11	512	0.59	0.63	08	0.4
12	1'024	0.29	0.31	07	0.3
13	2'048	0.15	0.16	06	0.3
14	4'096	0.073	0.078	05	0.2
15	8'192	0.037	0.039	04	0.2
16	16'384	0.018	0.020	03	0.2

* Recommended airgap = 0.2 mm. Sequence of A and B transitions is correct up to Maximum Airgap, but encoding specifications may be out of range.

Table 4: Look-Up Table (LUT)

D	Look-Up Table programmed in OTP
0	Not programmed
1	LUT according to scale, to be specified
8	Custom LUT, to be specified
9	Default LUT, no scale specified

Table 5: Linear scale (see Fig. 4)

EEEE	Scale	Description
00000	No scale	
01xxx	TPLS01	Cut to length xxx mm (5 – 205 mm)
02xxx	TPLS02	Cut to length xxx mm (5 – 550 mm)

Table 6: Encoder holder

F	Encoder holder
0	No holder
A	Holder type A (Fig. 5)
B	Holder type B (Fig. 3)

Table 7: Cable

GGG	Cable
000	No cable
0xx	Flat ribbon cable, length xx cm

Table 8: Connector

HH	Connector
00	No connector
01	6-pin conn. AMP MicroMaTch 7-215083-6
02	6-pin connector DIN 41651 (Fig. 6)
04	8-pin connector DIN 41651

© Copyright 2017 POSIC. All rights reserved. No part of this document may be reproduced without the prior written consent of POSIC. Products and companies mentioned in this document may be trademarks or registered trademarks of their respective owners. Information in this document is believed to be accurate and reliable and may be changed without notice. No responsibility is assumed by POSIC for its use, nor for infringements of patents or other rights of third parties which may result from its use. Some commercial or geographical restrictions may apply to the sale of this product. No license is granted by implication or otherwise under any patent or patent rights of POSIC. In no event shall POSIC, its employees, its contractors, or the authors of this document be liable for special, direct, indirect, or consequential damage, losses, costs, charges, claims, demands, claim for lost profits, fees, or expenses of any nature or kind. POSIC products are not designed, intended, authorized or warranted to be suitable for use in life-support applications, devices or systems or other critical care applications. Inclusion of POSIC products in such applications is understood to be undertaken solely at the customer's own risk. Should a customer purchase or use POSIC products for any such unauthorized application, the customer shall indemnify and hold POSIC and its officers, employees, subsidiaries, affiliates, representatives and distributors harmless against all claims, costs, damages and attorney fees which could arise.