

Product data

Features

- Highly miniaturized linear encoder in SMD-format
- Differential inductive sensing principle
- Insensitive to magnetic interference fields
- Robust against oil, water, dust, particles
- Programmable resolution and maximum speed
- Optional with cable, connector and holder

Applications

- Brushed and brushless motors
- Industrial and laboratory automation
- Rotary stages
- Robotics, assembly equipment
- High-speed motion control

Key Specifications

Output format.....A and B in quadrature
 Resolution.....128 up to >1'000'000 CPR
 Maximum speedup to 23'000 RPM
 Airgapup to 0.6 mm
 Supply.....5 V, 10 mA
 Temperature-20 to 100°C

Description

The ID4501C incremental encoder kit consists of an encoder and a codewheel (Fig. 1). The encoder is an integrated circuit in a PCB housing in SMD-format. It provides incremental A and B output signals in quadrature (Fig. 2). The codewheel is a PCB with passive copper strips. The orientation of the encoder is selected in Table 1.

Resolution, maximum speed and airgap

The resolution and the maximum speed of the encoder are user-programmable or can be programmed ex-factory. The resolution depends on a filter setting that limits the maximum speed of the encoder vs. the codewheel. The resolution also depends on the maximum distance between the encoder and the codewheel. The resolution and maximum speed for a certain maximum air-gap are selected in Tables 2 and 3.

Codewheel

The codewheels are shown in Fig. 4 and are selected in Table 5. The codewheel may be mounted on a hub, using a rim for accurate positioning in front of the encoder.

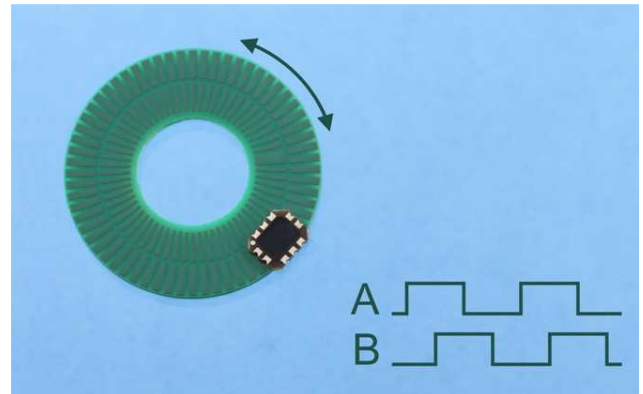
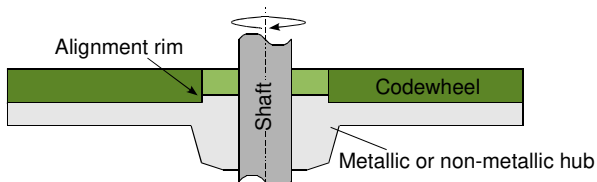

Encoder assembly

The encoder can be assembled by reflow soldering on a rigid or flexible PCB. Optimum performances are obtained by following the recommended schematic (Fig. 5) and footprint (Fig. 6). In particular, there should be no copper traces or metal objects behind the encoder up to a distance of 3 mm in order to avoid any influence on the measured position. If this is not possible, a blank copper layer behind the encoder (rear-side of the PCB) may be envisaged and/or a linearization using the on-chip look-up table (LUT).



Encoder holder

The encoder holder **type A** is available (Fig. 7) and can be selected in Table 6. It includes the encoder and the external components according to the recommended schematic (Fig. 5). The encoder holder can be mounted on any substrate using 4 screw holes.

Encoder cable and connector

The encoder on holder can be supplied with a flat cable of pitch 1.27 mm and a connector (Fig. 7). The cable length and the connector type are selected in Tables 7 and 8.

Encoder programming

The Evaluation and Programming Tool (EPT) including an interface board and the ASSIST software is available for the linearization and programming of the encoder.

3D models of encoder, holder and scales

STEP models are available on www.posic.com.

Specifications

Recommended Operating Conditions

Parameter	Symbol	Remark	Min	Typ	Max	Unit
Supply voltage	VDD		4.5	5.0	5.5	V
Operating Temperature	T _A		-20		100	°C
Airgap	Z			0.2		mm
Radial play and eccentricity	ΔY				0.1	mm
Airgap tolerance	ΔZ				0.1	mm

Electrical Characteristics

Electrical characteristics over recommended operating conditions, typical values at VDD = 5.0 V, T_A = 25°C.

Parameter	Symbol	Remark	Min	Typ	Max	Unit
Supply current	I _{DD}	No load	8	10	15	mA
Maximum output frequency	F	A/B output signals	0.8	1	1.2	MHz
High level output voltage*	V _{OH}	I _L = 2 mA	VDD-0.5			V
Low level output voltage*	V _{OL}	I _L = 2 mA			0.5	V
Rise time, fall time	t _r , t _f	C _L = 47 pF			20	ns

If A is pulled up and B pulled down during power-up, the encoder enters into a test mode with a 50 kHz square wave on all outputs.

Encoding Characteristics

Encoding characteristics over recommended operating conditions, typical values at VDD = 5.0 V, T_A = 25°C, airgap = 0.2 mm, speed = max speed/10.

Parameter	Symbol	Remark	Min	Typ	Max	Unit
Pulse width error	ΔP	Nominal value 180°e		10	50	°e
State width error	ΔS	Nominal value 90°e		10	60	°e
Phase shift error	ΔΦ	Nominal value 90°e		10	45	°e

Linearity

For high-resolution high-precision applications, it is possible to linearize the encoder by means of a Look-Up Table (LUT) that is located inside the encoder. The LUT can be programmed in volatile or in non-volatile memory by means of the Evaluation and Programming Tool (EPT) or it can be pre-programmed by POSIC. The LUT option is selected in Table 4.

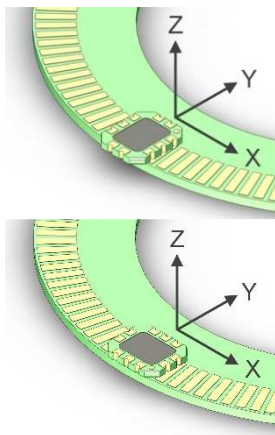

Fig. 1 Coordinate system XYZ.

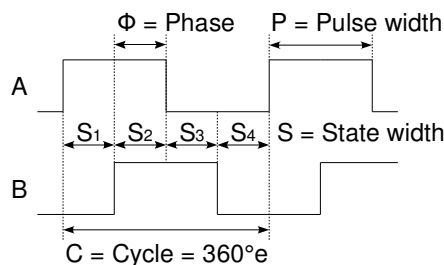

Fig. 2 Encoder output signals A and B in quadrature.

Definitions

- Airgap Distance between encoder and scale in Z-direction. See Fig. 1.
- Cycle One A quad B period, see Fig. 2.
- CPP Cycles per scale-period.
- °e Electrical degree (one Cycle is 360°e)
- Phase shift Φ Number of electrical degrees between the center of the high state of channel A and the center of high state of channel B. Nominal 90°e. Fig. 2.
- Pulse width P Number of electrical degrees that an output is high during one cycle. Nominal 180°e. Fig. 2.
- RPM Revolutions Per Minute (of the Codewheel)
- State width S Number of electrical degrees between two neighbouring A and B transitions. Nominal value is 90°e. See Fig. 2.

Technical drawings

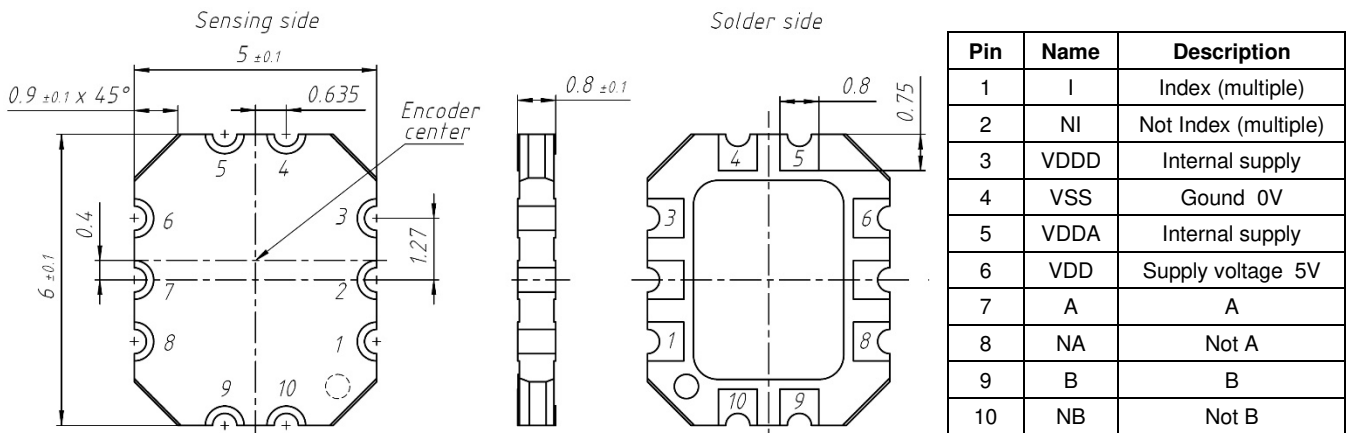
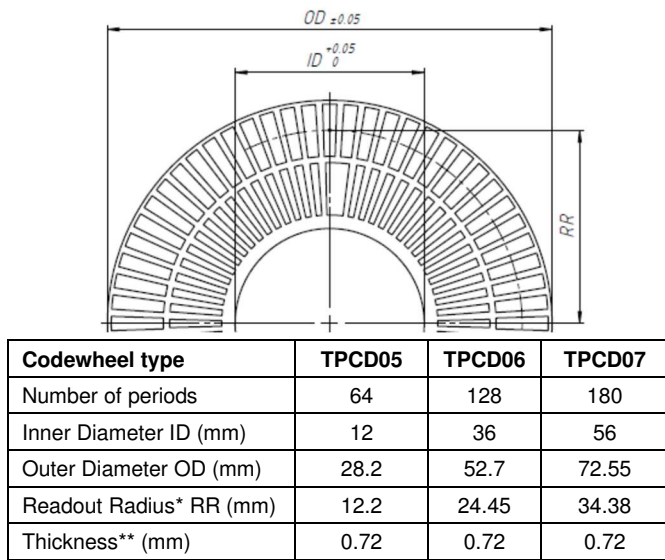

Fig. 3 Encoder dimensions (mm) and pin-out. "Encoder center" must be centered with respect to Readout Radius (see Fig. 4).



* Readout Radius = position of encoder center
 ** Thickness tolerance +/- 10% of thickness

Fig. 4 Codewheel dimensions. Only the external track is used.

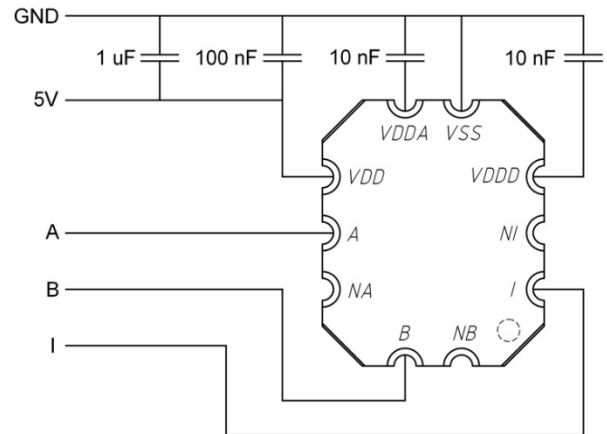

Fig. 5 Recommended schematic. The supply filter capacitor should be 1µF or more. The capacitors 100nF and 2 x 10nF should be placed close to the device. Connections A, B and I are required for programming and linearization.

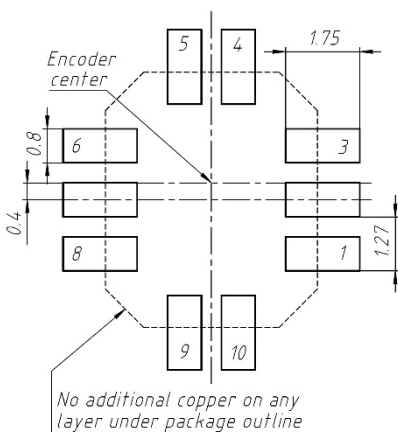

Fig 6 Recommended footprint.

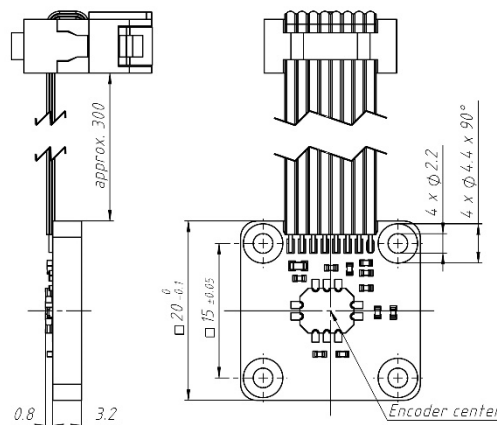

Fig. 7 Dimensions (mm) and connector pin-out of encoder on holder type A with flat cable (pitch 1.27 mm) and 8-pin DIN41651 connector.

Pin	Name	Description
1	VDD	5V Supply
2	VSS	Ground
3	A	A
4	B	B
5	I	I (multiple)
6	NA	Not A
7	NB	Not B
8	NI	Not I (multiple)

Ordering information

Ordering code: ID4501L-ABBCCD-EEEE-F-GGG-HH

A	Orientation	Table 1
BB	Maximum speed	Table 2
CC	Resolution	Table 3
D	Look-Up Table	Table 4
EEEE	Codewheel	Table 5
F	Encoder holder	Table 6
GGG	Cable	Table 7
HH	Connector	Table 8

Table 1: Orientation. Arrows indicate direction of movement of the scale with rising edge A prior to B.

A	Orientation
0	Not progr.
3	0°
4	90°
5	180°
6	270°

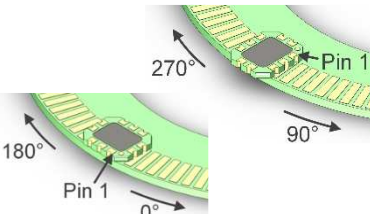

Table 2: Maximum speed

BB	Max speed (RPM)			Max value CC
	Nr. of periods on Codewheel			
	64	128	180	
00	Not programmed			
01	11	5	4	16
02	22	11	8	16
03	45	22	16	16
04	91	45	32	15
05	183	91	65	14
06	366	183	130	13
07	732	366	260	12
08	1'465	732	521	11
09	2'930	1'465	1'042	10
21	5'859	2'930	2'083	09
22	11'719	5'859	4'167	08
23	23'438	11'719	8'333	07

Lower Max speed leads to a lower jitter of the A/B outputs.

Table 3: Resolution

CC	Resolution CPR			Max value BB	Max Airgap* (mm)
	Nr. of periods on Codewheel				
	64	128	180		
00	Not programmed				
03	128	256	360	23	0.6
04	256	512	720	23	0.6
05	512	1'024	1'440	23	0.6

06	1'024	2'048	2'880	23	0.6
07	2'048	4'096	5'760	23	0.6
08	4'096	8'192	11'520	22	0.5
09	8'192	16'384	23'040	21	0.5
10	16'384	32'768	46'080	09	0.4
11	32'768	65'536	92'160	08	0.4
12	65'536	131'072	184'320	07	0.3
13	131'072	262'144	368'640	06	0.3
14	262'144	524'288	737'280	05	0.2
15	524'288	1'048'576	1'474'560	04	0.2
16	1'048'576	2'097'152	2'949'120	03	0.2

* Recommended airgap = 0.2 mm. Sequence of A and B transitions is correct up to Max Airgap, but encoding specifications may be out of range.

Table 4: Look-Up Table (LUT)

D	Look-Up Table programmed in OTP
0	Not programmed
1	LUT according to codewheel, to be specified
8	Custom LUT, to be specified
9	Default LUT, no codewheel specified

Table 5: Codewheel (see Fig. 4)

EEEE	Codewheel	Description
00000	No codewheel	
05064	TPCD05-064	64 periods, OD 28.2 mm
06128	TPCD06-128	128 periods, OD 52.7 mm
07180	TPCD07-180	180 periods, OD 72.6 mm

Table 6: Encoder holder

F	Encoder holder
0	No holder
A	Holder type A (Fig. 7)

Table 7: Cable

GGG	Cable
000	No cable
0xx	Flat ribbon cable, length xx cm

Table 8: Connector

HH	Connector
00	No connector
04	8-pin connector DIN 41651 (Fig. 7)

© Copyright 2021 POSIC. All rights reserved. No part of this document may be reproduced without the prior written consent of POSIC. Products and companies mentioned in this document may be trademarks or registered trademarks of their respective owners. Information in this document is believed to be accurate and reliable and may be changed without notice. No responsibility is assumed by POSIC for its use, nor for infringements of patents or other rights of third parties which may result from its use. Some commercial or geographical restrictions may apply to the sale of this product. No license is granted by implication or otherwise under any patent or patent rights of POSIC. In no event shall POSIC, its employees, its contractors, or the authors of this document be liable for special, direct, indirect, or consequential damage, losses, costs, charges, claims, demands, claim for lost profits, fees, or expenses of any nature or kind. POSIC products are not designed, intended, authorized or warranted to be suitable for use in life-support applications, devices or systems or other critical care applications. Inclusion of POSIC products in such applications is understood to be undertaken solely at the customer's own risk. Should a customer purchase or use POSIC products for any such unauthorized application, the customer shall indemnify and hold POSIC and its officers, employees, subsidiaries, affiliates, representatives and distributors harmless against all claims, costs, damages and attorney fees which could arise.