

Encoders

This assembly guide is applicable to the following types of POSIC encoders:

Cabled encoders: ID1102, IT3402, IT3403, AP3403
SMD encoders: ID4501, IT5602, AP5602

Electro-Static Discharge

POSIC encoders are ESD-sensitive devices and are delivered in ESD-protected carriers. The encoders should be handled with regular ESD-precautions.



Mechanical handling

Avoid mechanical impact on the sensing side of the encoder (Fig. 1), bending of the encoder (Fig. 2) and bending of the solder joints (Fig. 3). If it is necessary to press on the sensing side during assembly, it is recommended to press with a soft surface that spreads the force over the complete surface, such as a finger tip or a rubber-like flat surface.

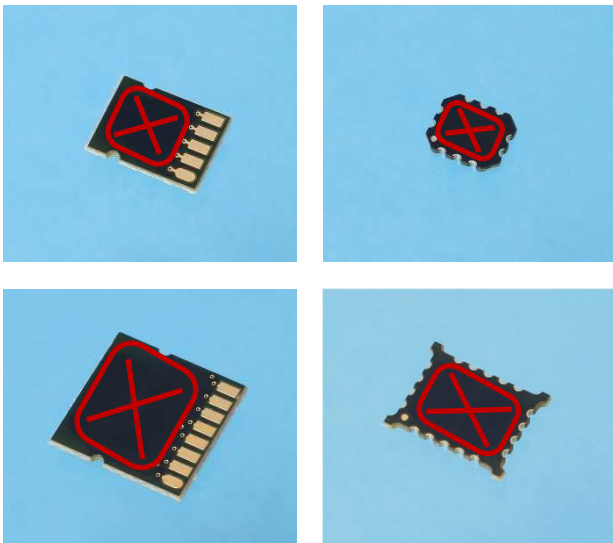

Fig. 1 Avoid mechanical impact on the sensing-side.



Fig. 2 Avoid bending of the encoder.

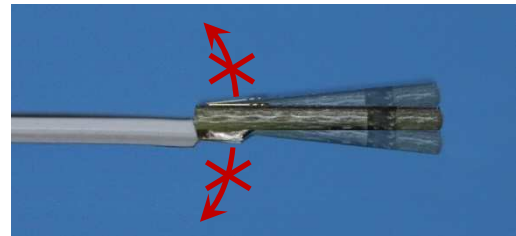

Fig. 3 Avoid bending of the solder joints.

Encoder holder

For cabled encoders, it is recommended to order them on a holder type A or B (see encoder datasheets). These holders shield the encoder against metallic structures that might be present behind the encoder after assembly and that could degrade encoder performance. If the encoder is mounted on a non-metallic surface of ≥ 2 mm thickness, no holder is required.

Encoder alignment

The cabled encoders have two half-holes as shown in Fig. 4. The encoder-center is in the middle between these two half-holes. It is recommended to align the encoder using these two half-holes with 2 alignment pins with diameter 1 mm.

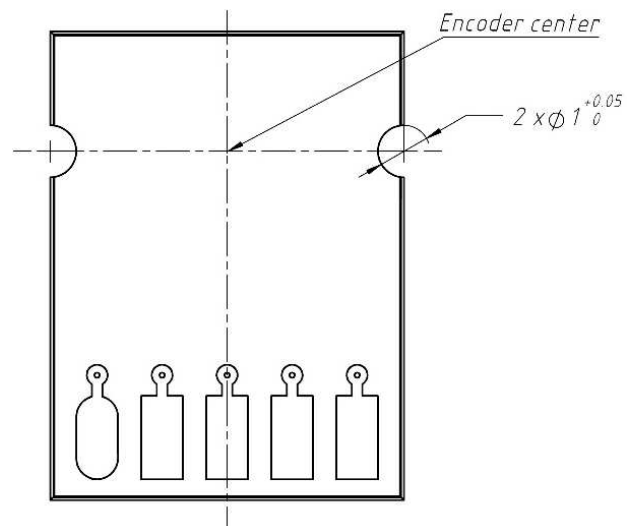

Fig. 4 Example of the half-holes for alignment in cabled encoder ID1102.

Adhesive

To mount an encoder, a holder, a codewheel or a scale into an application, please select an appropriate adhesive and follow the manufacturer's recommendations. Example: Henkel Loctite® 480 for metallic surfaces.

Soldering cabled encoders

If a "cabled encoder" has been ordered without cable, the following precautions must be taken when soldering a cable:

- Solder swiftly in order to avoid un-necessary heating of the device.
- Use a heat-sink in order to evacuate the heat.

Overheating an encoder during soldering may lead to permanent damage.

Soldering SMD-encoders

SMD-encoders can be soldered on a printed circuit board using industry standard reflow techniques. Fig. 5 shows the recommended temperature profile and Table 1 shows the specifications for soldering with a commercial SAC405 solder paste. It is recommended not to solder SMD-encoders by hand.

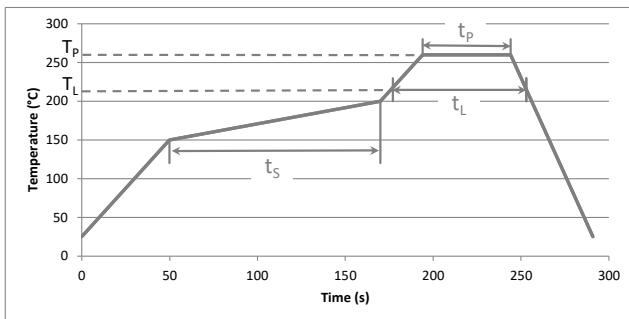

Fig. 5 Recommended soldering profile.

Table 1 Soldering specifications.

Param	Remark	Min	Max	Unit
T_L	For SAC405	217	218	°C
T_P			260	°C
t_s	$T = 150 - 200^{\circ}\text{C}$	60	180	s
t_L	$T > T_L$	60	150	s
t_P	$T = T_P - 5^{\circ}\text{C}$ to T_P	20	40	s
$\Delta T/\Delta t$	During ramp-up		3	°C/s
	During ramp-down		6	°C/s

Moisture sensitivity

POSIC encoders are specified to Moisture Sensitivity Level (MSL) 3 according to IPC/JEDEC J-STD-033. This corresponds to a floor life of 168 hours.

If the devices were not supplied or stored in a sealed moisture barrier bag or if the floor life has been exceeded, the devices must be dried according to IPC/JEDEC J-STD-033 prior to soldering: 4 hours at 125°C or 4 days at 40°C.

Output stage

The circuit diagram of the output stage of the A/B/I outputs of cabled and SMD encoders is shown in Fig. 6. The output stage may be operated without load, with pull up, with pull down or with differential load resistor. The ID4501 has differential outputs, all other encoders have single-ended outputs.

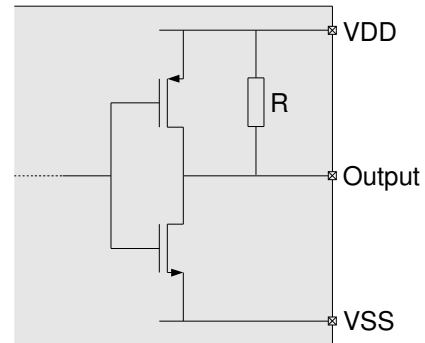

Fig. 6 Schematic diagram of the output stage of a POSIC encoder. The encoder-internal pull up resistor R is typically around 50 kΩ.

The output current as a function of the resistance value of a pull up, pull down or a differential load resistor is shown in Fig. 7.

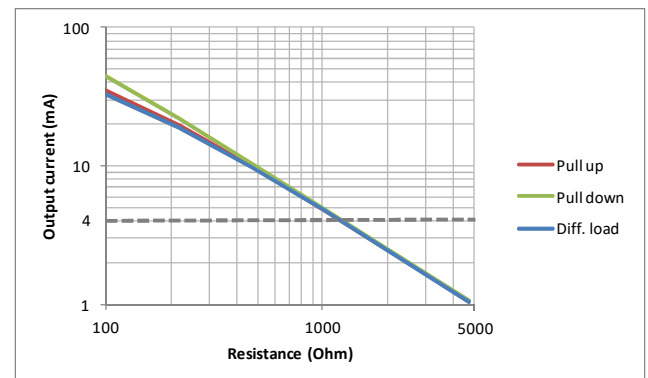

Fig. 7 Typical output current at 25°C as a function of pull up, pull down or differential load resistance.

If load resistors are required for your application, it is recommended to select a resistance value above 1 kΩ, which corresponds to an output current below 4 mA (maximum output current according to datasheet).

For higher output currents and voltages, POSIC proposes interface boards with RS422 or open collector outputs.

Note: if a pull up resistor is connected to A and a pull down resistor to B during power-up of the encoder, the encoder will enter into a test-mode in which all outputs toggle on/off with a frequency between 50 and 100 kHz. In order to assure correct power-up of the encoder (no test-mode), it is recommended to use either 1) pull up resistors to A and B or 2) pull down resistors to A and B or 3) no pull up/down resistors

Scales and Codewheels

Stroke of a linear scale

For correct operation over the full stroke (movement between encoder and scale), the scale should extend 3 periods beyond the stroke at each end of the scale, as illustrated in Fig. 8. The extension can be reduced to 2 periods or even 1 period at each end of the scale, however, this may lead to an increase in non-linearity towards the end of the stroke.

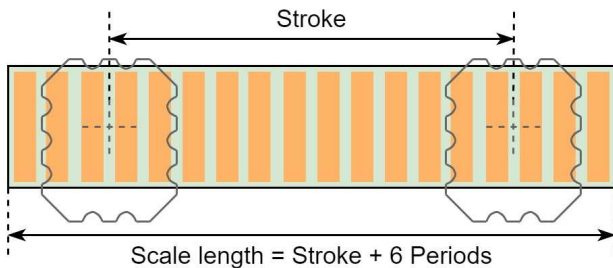

Fig. 8 Recommended scale length is 3 periods beyond the stroke at each end of the scale

Scale alignment

A scale can be aligned using a < 0.2 mm high alignment edge along the full length of the scale, as shown in Fig. 9. Alternatively, alignment edges higher than 0.2 mm, but lower than the height of the scale, can be used outside the stroke (movement range), as shown in Fig. 10.

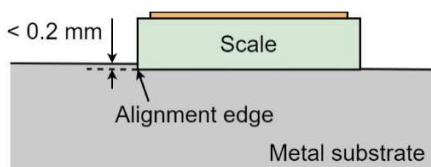

Fig. 9 Alignment of a scale against an alignment edge with height < 0.2 mm.

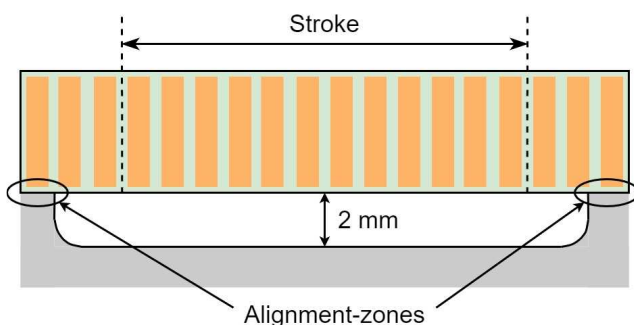

Fig. 10 Alignment of a scale against two alignment edges. The alignment edges are outside the stroke and may be higher than 0.2 mm.

Codewheel alignment

A codewheel can be aligned using 3 alignment pins with diameter 1 mm as shown in Fig. 11.

Alternatively, a < 0.2 mm high alignment edge along the inner diameter of the codewheel can be used, as shown in Fig. 12.

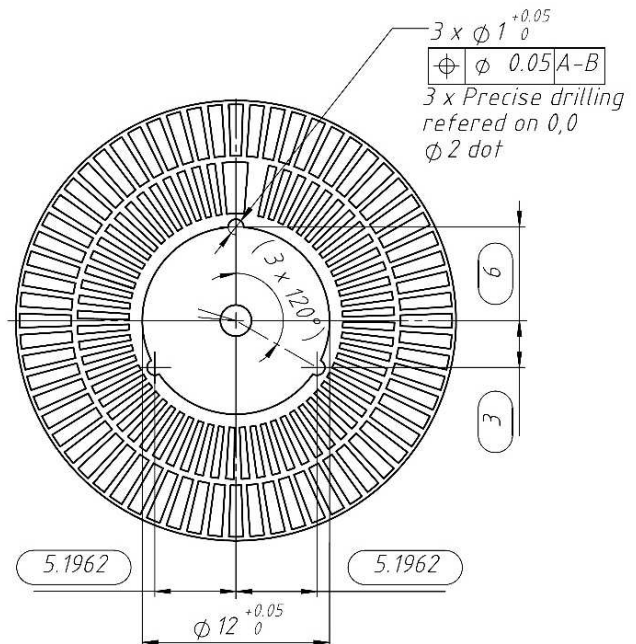

Fig. 11 Technical drawing of the TPCD05 codewheel with the dimensions for alignment purposes.

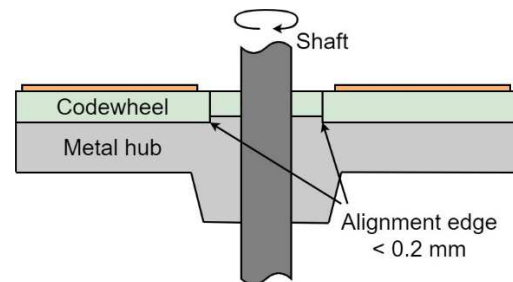

Fig. 12 Alignment of a codewheel against an alignment edge with height < 0.2 mm.

© Copyright 2020 POSIC. All rights reserved. No part of this document may be reproduced without the prior written consent of POSIC. Products and companies mentioned in this document may be trademarks or registered trademarks of their respective owners. Information in this document is believed to be accurate and reliable and may be changed without notice. No responsibility is assumed by POSIC for its use, nor for infringements of patents or other rights of third parties which may result from its use. No license is granted by implication or otherwise under any patent or patent rights of POSIC. In no event shall POSIC, its employees, its contractors, or the authors of this document be liable for special, direct, indirect, or consequential damage, losses, costs, charges, claims, demands, claim for lost profits, fees, or expenses of any nature or kind.