

## Product data

### Features

- Single-ended inputs, open collector outputs
- Small size, easy to connect
- Compatible to ASSIST Evaluation & Programming Tool
- Suitable for development and for small series production

### Key Specifications

Inputs .....	Single-ended 5V TTL/CMOS
Outputs .....	Open collector NPN or PNP
Supply voltage .....	9 – 48 V DC
Output current.....	100 mA
Frequency.....	0 – 100 kHz
Temperature .....	-40 to 85°C
Overtoltage protection.....	up to 50V
Reverse polarity protection ....	down to -12V
Short circuit protection .....	each output

### Description

The Open Collector Interface Board has the following functions:

- Conversion of single-ended 5V TTL or CMOS encoder signals to NPN or PNP open collector signals
- Configuration and/or programming of the encoder via the ASSIST Interface Board

### Encoder Power

The three ways to power the encoder are explained below.

Encoder power from Open collector: put the Encoder Power jumper in place. Do not connect the ASSIST Board.

Encoder power from ASSIST Board: remove the Encoder Power jumper, so that the open collector power supply may be connected or not.

Configure the encoder using the ASSIST Board, then switch to open collector power:

- 1) Remove the Encoder Power Jumper
- 2) Connect the open collector connections, including supply pin 1 (Fig. 3)
- 3) Connect the ASSIST Board
- 4) Start the ASSIST software and configure the encoder
- 5) In the ASSIST software go to the evaluation window and start the encoder (the encoder is now powered by the ASSIST Board)
- 6) Put the Encoder Power jumper in place (the encoder is now powered by two sources with the same voltage)
- 7) Disconnect the ASSIST Board connector (the encoder is now powered by the open collector supply voltage)



Fig 1 Open Collector Board.

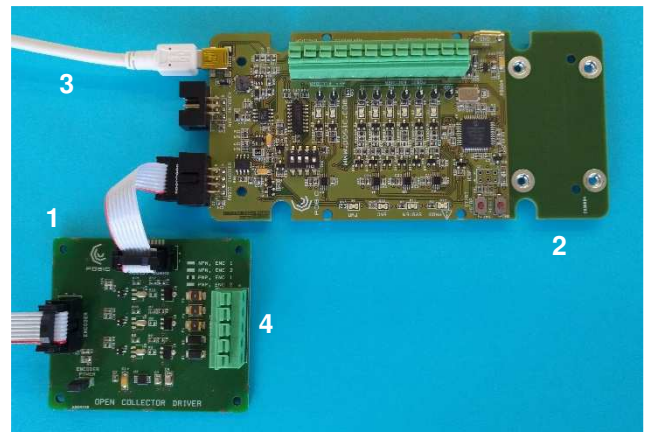

Fig 2 Open Collector Board (1) connected to ASSIST Interface Board (2), which is connected via USB cable (3) to a PC with ASSIST software. The open collector outputs (4) are available on the green terminal block.

### In/outputs

The input signals may be on different pins of the Encoder connector and are selected in Table 1.

The output type may be NPN or PNP and is selected in Table 2.

### Connectors

The 8-pin DIN41651 connectors on the Open Collector Board are compatible to the ASSIST Interface Board, see Fig 2.

## Specifications

### Absolute Maximum Ratings

Parameter	Symbol	Remark	Min	Typ	Max	Unit
Supply voltage	$V_S$	Overtoltage and reverse polarity	-12		50	V DC
Storage Temperature	$T_S$	No supply voltage applied	-40		125	°C

### Recommended Operating Conditions

Parameter	Symbol	Remark	Min	Typ	Max	Unit
Supply voltage	$V_S$		9		48	V
Ripple		On supply voltage VDD			10	%
Operating Temperature	$T_A$	$V_S = 24 - 48\text{ V}$ $V_S = 9 - 24\text{ V}$	-40	25	60 85	°C
Load resistance	$R_L$	$V_S = 24 - 48\text{ V}$ $V_S = 9 - 24\text{ V}$	100 50			$\Omega$

### Electrical Characteristics

Electrical characteristics over recommended operating conditions, typical values at VDD = 5.0 V,  $T_A = 25^\circ\text{C}$ .

Parameter	Symbol	Remark	Min	Typ	Max	Unit
Supply current	$I_S$	$V_S = 24\text{ V}$ , ID-encoder, signals 50% duty cycle, 3 outputs, $R_L = 100\ \Omega$		400		mA
Frequency	F	Output signals	0		100	kHz
High level input voltage	$V_{IH}$		4.5			V
Low level input voltage	$V_{IL}$				0.5	V
Output current	$I_{out}$	Per output			100	mA
Voltage drop	$V_{drop}$	$I_{out} = 100\text{ mA}$			2	V
Rise time	$t_r$	$V_S = 24\text{ V}$ , $R_L = 50\ \Omega$			5	$\mu\text{s}$
Fall time	$t_f$	$V_S = 24\text{ V}$ , $R_L = 50\ \Omega$			10	$\mu\text{s}$

### Technical drawings

Pin	Encoder	ASSIST Board	Output
1	VDD, 5V Supply	VDD, 5V Supply	Supply (9 – 48 V)
2	GND, Ground	GND, Ground	GND, Ground
3	A1	A1	A
4	B1	B1	B
5	I1	I1	I
6	A2	A2	-
7	B2	B2	-
8	I2	I2	-

Fig 3 Pinout of the connectors.

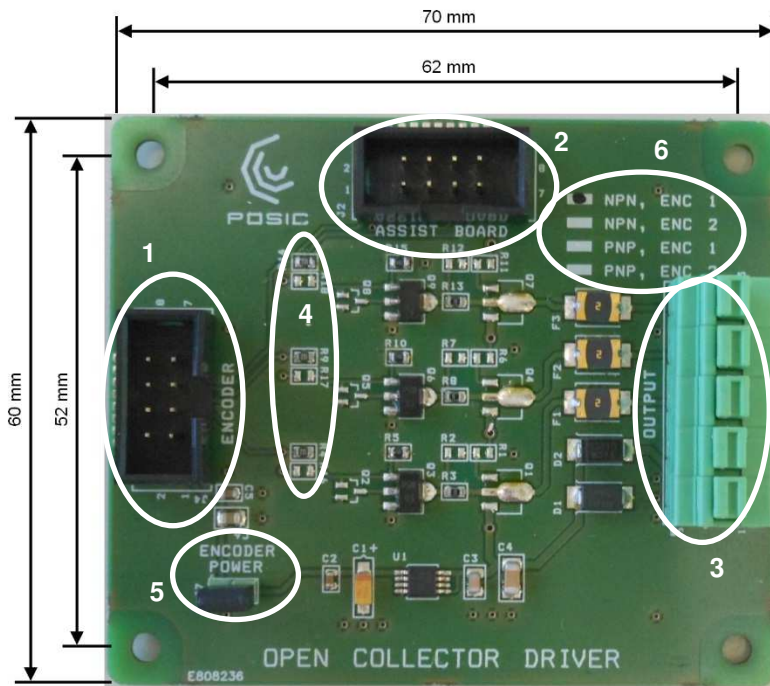

**Connectors:**

- 1) Encoder (single ended 5V TTL/CMOS)
- 2) ASSIST Interface Board
- 3) Output (open collector)

**Input selection (by means of resistors), see Table 1:**

- 4) Select encoder 1 (A1, B1, I1 via R4, R9, R14 resp.) or encoder 2 (A2, B2, I2 via R16, R17, R18 resp.)

**Encoder power selection:**

- 5) Jumper
  - Present: encoder powered by Open Collector supply
  - Removed: encoder powered by ASSIST Interface Board

**Configuration:**

- 6) Configuration, see Tables 1 and 2

Fig. 4 Dimensions and explanations for a board with encoder 1 connected and NPN outputs. The connectors for the POSIC encoder and the ASSIST Board are 8-pin DIN41651

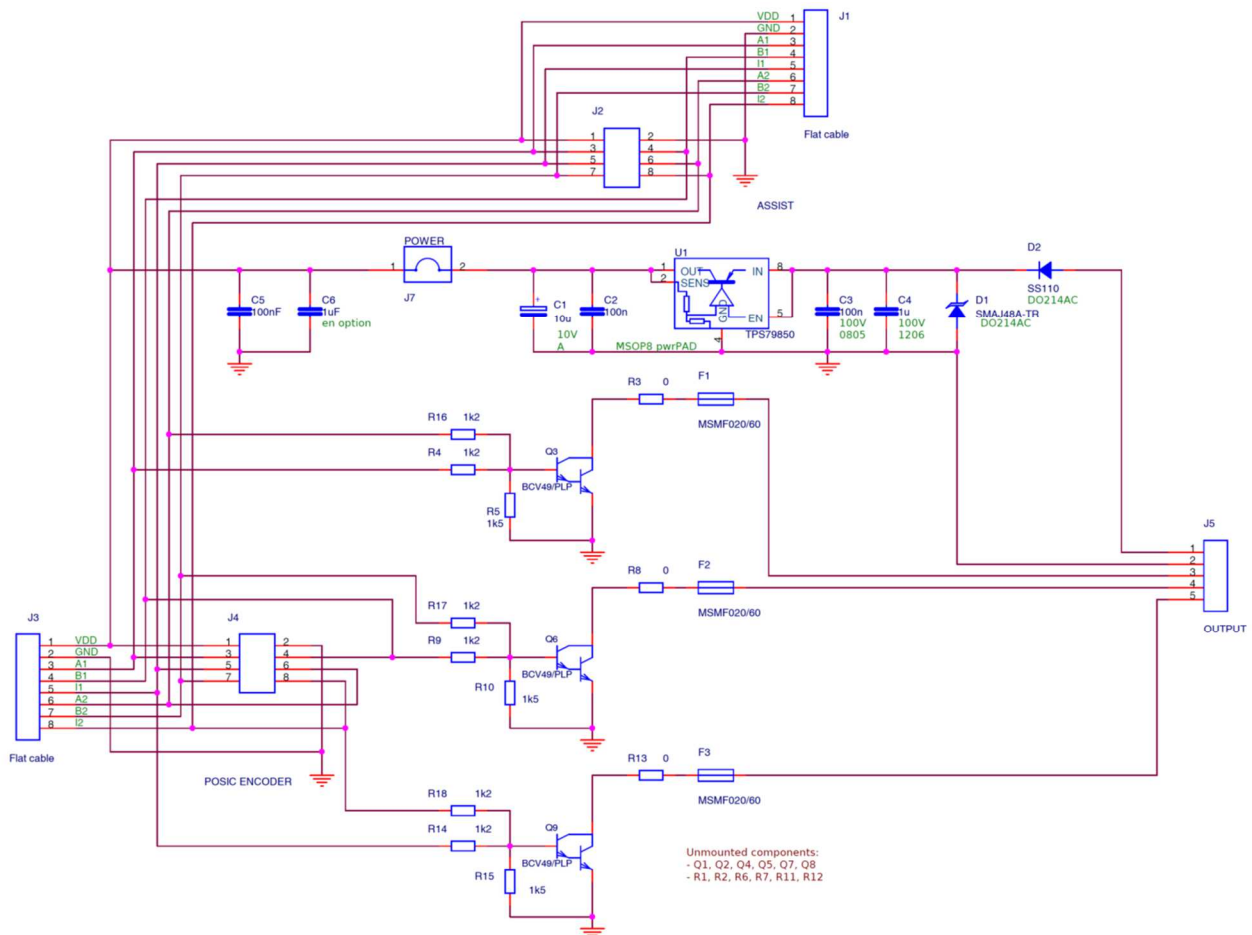

Fig. 5 Schematic diagram with NPN outputs. Selection of the inputs (see Table 1): R4, R9, R14 for encoder 1; R16, R17, R18 for encoder 2.

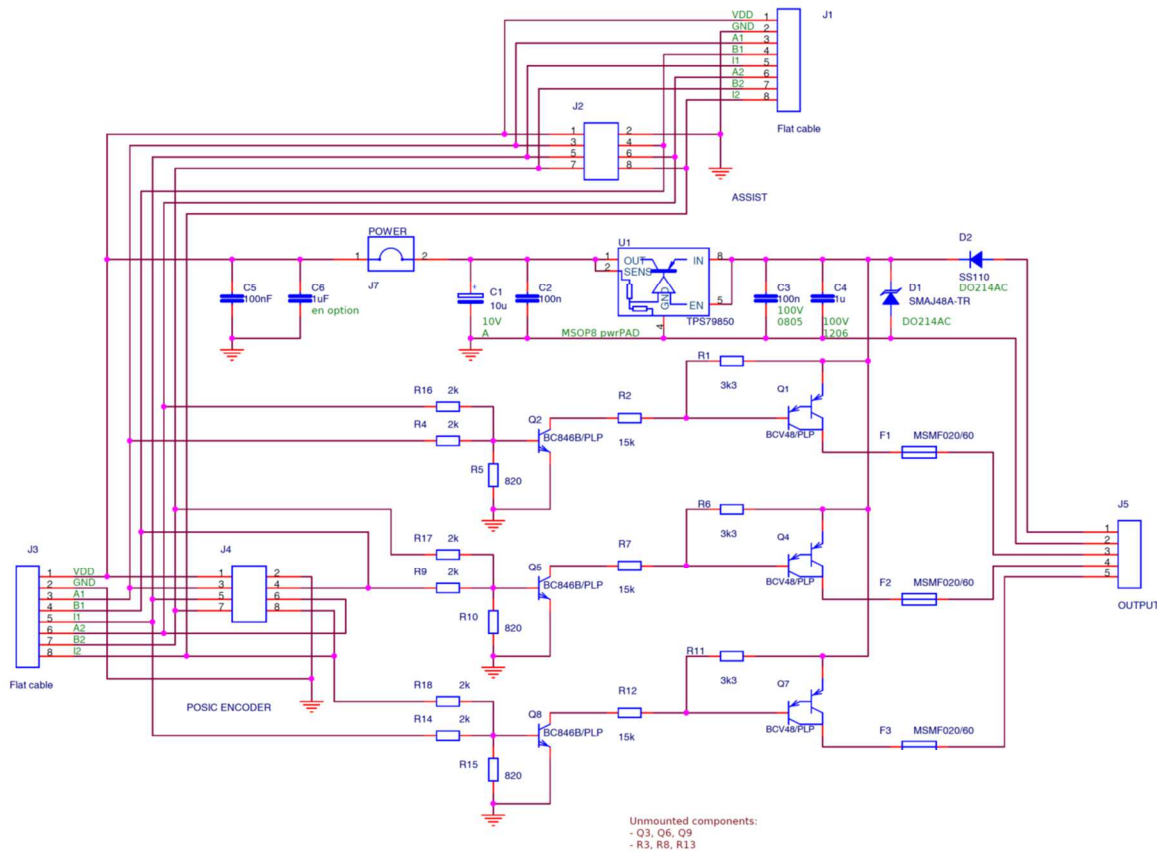

Fig. 6 Schematic diagram with PNP outputs. Selection of the inputs (see Table 1): R4, R9, R14 for encoder 1; R16, R17, R18 for encoder 2.

### Ordering information

Open Collector Interface Board including flat cable for connection to ASSIST Interface Board.

Code: OCB001-ABC

- |   |                  |         |
|---|------------------|---------|
| A | Input selection  | Table 1 |
| B | Output selection | Table 2 |
| C | Connectors       | Table 3 |

Table 3: Connectors mounted on the board

C	Connectors J2, J4, J6 and jumper J7*
5	All connectors/jumper soldered on the board

\* See schematic diagrams in Fig 5 and Fig 6.

Table 1: Input selection

A	Input selection	Suitable for encoders
0	Inputs not defined	-
1	Inputs A1, B1, I1	ID1102, ID4501
2	Inputs A2, B2, I2	IT3402, IT5602

Table 2: Output selection

B	Output selection
1	NPN
2	PNP

© Copyright 2021 POSIC. All rights reserved. No part of this document may be reproduced without the prior written consent of POSIC. Products and companies mentioned in this document may be trademarks or registered trademarks of their respective owners. Information in this document is believed to be accurate and reliable and may be changed without notice. No responsibility is assumed by POSIC for its use, nor for infringements of patents or other rights of third parties which may result from its use. Some commercial or geographical restrictions may apply to the sale of this product. No license is granted by implication or otherwise under any patent or patent rights of POSIC. In no event shall POSIC, its employees, its contractors, or the authors of this document be liable for special, direct, indirect, or consequential damage, losses, costs, charges, claims, demands, claim for lost profits, fees, or expenses of any nature or kind. POSIC products are not designed, intended, authorized or warranted to be suitable for use in life-support applications, devices or systems or other critical care applications. Inclusion of POSIC products in such applications is understood to be undertaken solely at the customer's own risk. Should a customer purchase or use POSIC products for any such unauthorized application, the customer shall indemnify and hold POSIC and its officers, employees, subsidiaries, affiliates, representatives and distributors harmless against all claims, costs, damages and attorney fees which could arise.